

Wood Stone



WS-FD-11260-RFG-LR-IR configuration shown.

HEARTH CAPACITY

8" pizzas:	50	16" pizzas:	10
10" pizzas:	32	18" pizzas:	8
12" pizzas:	18	20" pizzas:	6

Assuming 5-minute cook times, the approximate maximum hourly production capacity can be calculated by multiplying the above numbers by 12. Cook times will also vary depending on "style" of pizza. **Note:** The addition of an optional decorative flame will decrease space and impact overall cooking capacity.

GUIDE TO MODEL NUMBERS

	Underfloor IR Burner	Left Side Radiant Flame	Right Side Radiant Flame	Decorative Flame (-DF)	Wood Required	Combination	Natural Gas	Liquid Propane
WS-FD-11260-RFG-LR-IR	X	X	X	-DF			-NG	-LP
WS-FD-11260-RFG-LR-IR-W	X	X	X		X		-NG	-LP
WS-FD-11260-RFG-L-IR-W	X	X			X	X	-NG	-LP
WS-FD-11260-RFG-R-IR-W	X		X		X	X	-NG	-LP
WS-FD-11260-W-IR	X				X		-NG	-LP
WS-FD-11260-W					X			

FIRE DECK 11260 STONE HEARTH OVEN



Job Name	
Model	WS-FD-11260
Item#	

The Fire Deck 11260 oven features a door opening 54 inches wide x 10 inches high with a stainless steel mantle at the hearth. The cooking area is 91 inches wide x 44 inches deep, resulting in a 28-square-foot cooking surface. A tensioned steel exoskeleton surrounding the hearth and dome perimeter ensures structural integrity and longevity. Wrapped in spun ceramic fiber insulation and requiring only a 1-inch side clearance to combustibles, the monolithic cast-ceramic 4-inch thick hearth and monolithic 4-inch thick dome rest on a black painted steel stand. The oven body front, top, back and sides are finished with galvanized steel. The oven arrives completely assembled, ETL Listed, ready to install and is made in the USA. A set of optional rigging casters is available to aid in the initial installation. Information about custom finishes, tools and accessories can be found online at: woodstone-corp.com.

FUEL CONFIGURATIONS

GAS-FIRED ONLY: Configured to burn either natural gas (NG) or liquid propane (LP).*

RADIANT FLAME + UNDERFLOOR IR (RFG-IR):

Heated by an adjustable radiant flame located on both sides of the cooking chamber, along with a thermostatically controlled infrared burner which is mounted under the oven deck to ensure high production capacity.

DECORATIVE FLAME (-DF): Provides an additional 15,000 BTU/hr flame at rear of cooking chamber for show.

WOOD-FIRED ONLY (W): Wood-fired only.

WOOD WITH GAS ASSIST (W-IR): This wood-fired model is assisted by the additional BTU/hr of an Underfloor IR burner. **Note:** A wood fire is required with this configuration.

COMBINATION (-W): Allows optional wood burning for ovens with gas burner configurations. **Note:** Adding wood to an oven with an RFG burner will reduce available hearth capacity.

COAL-FIRED (-CL): See Coal-Fired Oven (11260) 

*Gas type must be specified at time of order.



t. 360.650.1111
tf. 800.988.8103
f. 360.650.1166

Wood Stone Corporation
1801 W. Bakerview Rd.
Bellingham, WA 98226 USA
info@woodstone-corp.com
woodstone-corp.com

REVISED: SUMMER 2015

An ongoing program of product improvement may require us to change specifications without notice.





FIRE DECK 11260

STONE HEARTH OVEN • WS-FD-11260

A	Flue Collar
B	Mantle
C	Flame Height Control Knob
D	Digital Controller
E	Forklift Here
	Electrical Connection (accessible from inside or outside)
F	Service Panel or Optional Storage Box
G	Gas Connection
	Must Be Left Removable for Service
	AIR INTAKE: Do Not Facade or Cover Over

PLAN VIEW

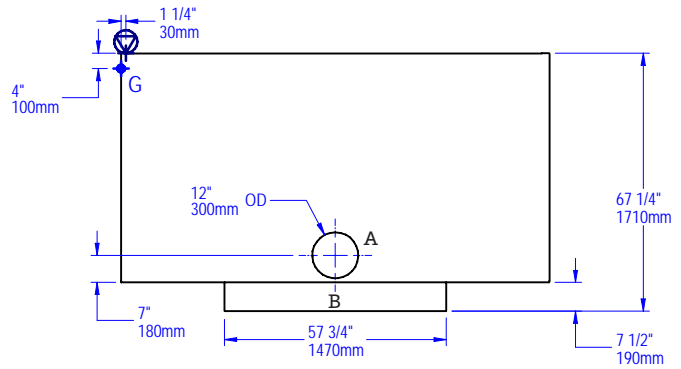

SIDE VIEW

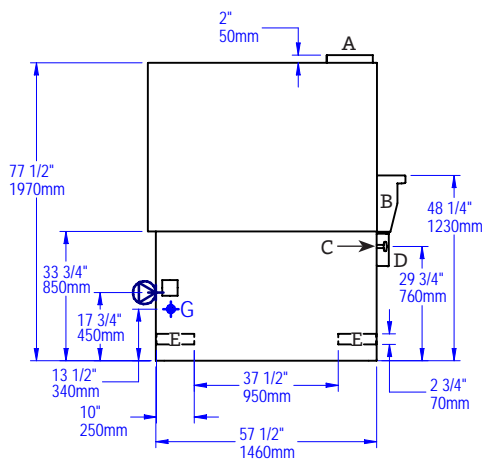

FRONT VIEW

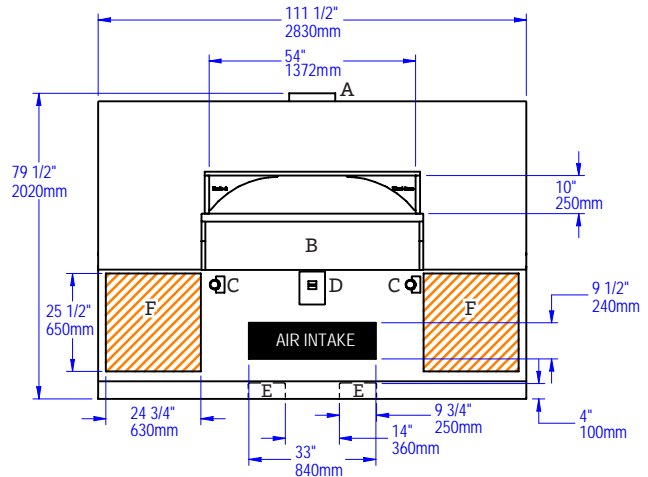

UTILITIES SPECIFICATIONS

GAS
Gas-Fired Only and Combination
 1 inch gas inlet (FNPT)
 350,000 BTU/hr - Natural Gas (NG)
 OR
 350,000 BTU/hr - Propane (LP)

	BTU/hr Output Per Burner	
Radiant Flame Burner	125,000 NG	125,000 LP
IR Burner	100,000 NG	100,000 LP
Decorative Flame Adds	15,000 NG	15,000 LP

ELECTRICAL
Gas-Fired Only and Combination
 120 VAC, 2 A, 50/60 Hz
 Connection is made on left side of oven as shown.

IMPORTANT: Models with -W or -CL in the model number must be vented as a solid fuel appliance.

VENTING INFORMATION

The Fire Deck 11260 can be direct connected to a power-ventilated, grease-rated chimney or be vented using a Listed Type 1 exhaust hood, or a hood constructed and installed in accordance with NFPA 96 and all relevant local and national codes. The oven must be vented in accordance with all relevant local and national codes, and in a manner acceptable to the authority having jurisdiction.

Ship Weight: 6,800 lbs / 3,084 kg

REVISED: SUMMER 2015

An ongoing program of product improvement may require us to change specifications without notice.



t. 360.650.1111
 tf. 800.988.8103
 f. 360.650.1166

Wood Stone Corporation
 1801 W. Bakerview Rd.
 Bellingham, WA 98226 USA
info@woodstone-corp.com
woodstone-corp.com

