

REFRIGERATOR MANUFACTURER
Turbo air
 more durable, efficient, beautiful

4184 E. Conant St.
 Long Beach, CA 90808
 Tel. 310-900-1000
 Fax. 310-900-1077
www.turboairinc.com

Project :	
Model # :	
Item # :	Qty :
Available W/H :	
Approval :	

Half Solid Door Refrigerator

Reach-In Top Mount
 M3 Series

Model : M3R72-6

FEATURES & BENEFITS

■ **Maintenance-free, Self-Cleaning Condenser (patented)** *Only at Turbo Air*

The accumulation of dust in the condenser causes the failure or breakdown of refrigerators. Refrigerators run normally until they reach a certain level of accumulation. At some point, when they are over the limit, their performance drops quickly resulting in damage to, or disposal of the stored products in refrigerators. The self-cleaning condenser device keeps the condenser clean and prevents system failure by automatically brushing daily.

■ **Digital temperature control & monitor system**

- Keep food products safe by maintaining constant temperatures.
- Alarms that sound when doors are not sealed shut; protect against food spoilage that originate from cold air leaks.
- Digital display allows for easy monitoring.
- Programs interpret the condition of refrigeration systems by self-diagnosis.
- Automatic evaporator fan motor delays.

■ **Hot gas condensate system** *Only Turbo Air models*

Through Turbo Air's creative innovation, the condensate system surfaces have been specially treated to resist corrosion. This not only increases efficiency without the risk of refrigerant leakage from corrosion, but also prevents the overflow of condensate water.

■ **Stainless steel cabinet construction**

The Turbo Air M3 refrigerator model boasts a stainless steel exterior (galvanized steel top, bottom and back) and stainless steel interior with AL inside walls and door liners. It guarantees the utmost in cleanliness and long product life. The sharp corners and edges have been rounded to reduce the risk of injury. The M3 can add a touch of style to the most refined setting.

■ **Door pressure release device** *Only Turbo Air models*

Pressure relief doors are designed to eliminate vacuum pressure and allows easy, instant door opening.

■ **Efficient refrigeration system**

M3's solid door refrigerators are designed with oversized and balanced (CFC Free R-134A) refrigeration systems. These include efficient evaporators and condensers for faster cooling and greater efficiency.

■ **LED interior lighting**

■ **Adjustable, heavy duty, PE(polyethylene) coated wire shelves**

■ **High-density polyurethane insulation**

The entire cabinet structure and solid doors are foamed-in-place using high density, CFC free polyurethane insulation.

■ **Top mount compressor**



Refrigerator holds 33°F ~ 38°F for the best in food preservation

Patented Self-Cleaning Condenser



This product is equipped with a fine mesh filter to the front of the condenser to catch dust, and a rotating brush that moves up and down daily to remove excess buildup outward and away.



Model	Swing Door	CU./FT.	#of Shelves	HP	AMPS	Crated Weight (lbs.)	L x D x H [†] (inches)
M3R72-6	6	65.6	9	1/2	11.3	559	77 3/4 x 30 3/4 x 78

Half Solid Door Refrigerator

Reach-In Top Mount
M3 Series

Model : M3R72-6

ELECTRICAL DATA	
Voltage	115/60/1
Plug Type	 NEMA 5-15P
Full Load Amperes	11.3
Compressor HP	1/2
Feed Wires with Ground	3
Cord Length (ft.)	9
Refrigerant	R-134A
DIMENSIONAL DATA	
# of Doors	6
# of Racks Accepted	3
Net Capacity (cu. ft.)	65.6
Ext. Length Overall (in.)	77 ³ / ₄ (1975mm)
Ext. Depth Overall (in.)*	30 ³ / ₄ (780mm)
Ext. Height Overall (in.)†	78 (1981mm)
Int. Length Overall (in.)	73 ⁷ / ₈ (1877mm)
Int. Depth Overall (in.)	26 ¹ / ₂ (675mm)
Int. Height Overall (in.)	60 ⁵ / ₈ (1539mm)
Gross Weight (lbs.)	559
# of Shelves	9
Shelf Size (L x D) (in.)	23 x 23 ¹ / ₂ (Left/Right)
	25 ¹ / ₄ x 23 ¹ / ₂ (Middle)

Design and specifications subject to change without notice.

Actual shipping weight may differ due to extra packing materials for product protection.

* Depth does not include 2" for rear condensate enclosure.

† Height does not include 5" for caster height.

■ WARRANTY : 3 Year Parts and Labor Warranty Additional 2 Year Warranty on Compressor

- Self-contained system
- Standard 4" dia. swivel casters with locks on the front set
- Door locks standard
- Magnetic door gaskets
- Solid and sturdy grille design
- Legs available (optional)
- Half size pan racks available (optional)

■ OPTIONAL ACCESSORIES :

- 5" caster, 1/2" diameter & 13 TPI: M726500100 (non-brake), M726500200 (w/ brake)
- 6" stainless steel leg: 30221M0600
- Additional PE coated wire shelf: G8F1800101 (Left/Right), G8F1800201 (Middle)
- Half door bun tray rack: TSP-2224 (each holds up to six 18"L x 26"D sheet pans)

Ver.201701

PLAN VIEW

(unit : inch)

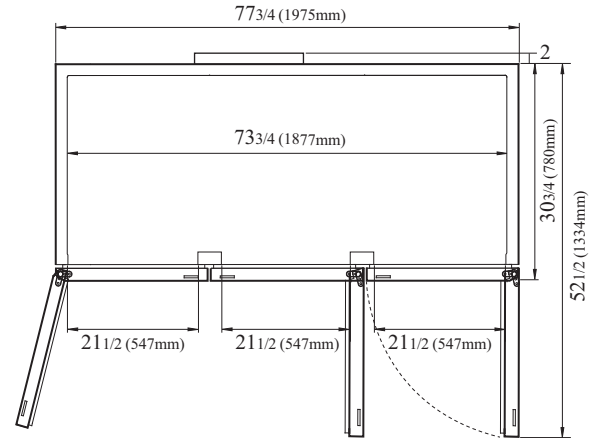

PLAN VIEW

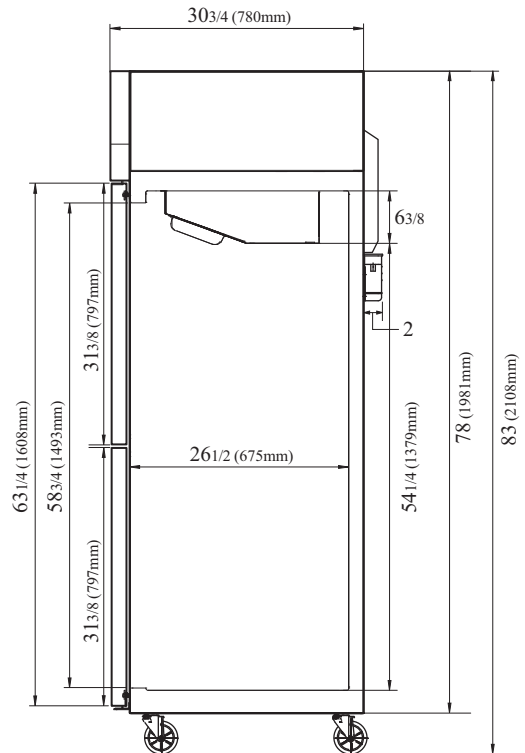

SIDE VIEW



- Turbo Air : 800-627-0032
- GK : 800-500-3519
- Warranty : 800-381-7770
- AC : 888-900-1002

REFRIGERATOR MANUFACTURER
Turbo air

GERMAN KNIFE

RADIANCE

GREEN WORLD

AIR CONDITIONER MANUFACTURER
Turbo air