



Project _____
 AIA # _____ SIS # _____
 Item # _____ Quantity _____ C.S.I. Section 114000



G-SERIES

1-Section Freezer Reach-In Self-Contained Solid Door(s)



Many models are ENERGY STAR® listed. Please refer to www.energystar.gov to view the most up-to-date product listing and performance data.



This unit is listed to the applicable UL, CSA and NSF Standards by an approved NRTL. Consult the factory or unit's data plate for approval information.

AVAILABLE CONFIGURATIONS

Half-Height Door Models

G12000
G12001

Hinging

Right
Left

Full-Height Door Models

G12010
G12011

Hinging

Right
Left

STANDARD PRODUCT FEATURES

- High Performance, Energy Efficient Refrigeration System
- Reliable Microprocessor Control With LED Temperature Display
- Evaporator Coil Outside Food Zone Provides More Usable Space
- Load-Sure Guard Prevents Problems From Improper Loading
- Durable All-Metal Construction
- Stainless Steel Front & Doors, Anodized Aluminum Sides & Interior
- Full or Half Height Door Models with a Variety of Hinging Configurations
- Long Life EZ-Clean Door Gasket(s)
- Three (3) Epoxy Coated Shelves Per Section (factory installed)
- Easy to Maintain Front Facing Condenser Coil
- 6" High Locking Casters
- Guaranteed for Life Door Handles & Hinges
- 3-Year Parts & Labor Warranty
- 2-Years Additional Compressor Parts Warranty

ACCESSORIES & OPTIONS (*field installed)

- ▣ Tray Slides for 18" x 26" Sheet Pans*
- ▣ Tray Slides for 12" x 20" Food Pans*
- ▣ Tray Slides for 14" x 18" Sheet Pans*
- ▣ Tray Slides for 18" x 26, 12" x 20" & 14" x 18" Pans*
- ▣ Additional Shelves*
- ▣ 6" High Legs*
- ▣ Lower Height Casters*
- ▣ Optional Remote Applications

*Please refer to form number TR35872 for precise kit details. See back page for tray slide versatility chart.

DEALERS CHOICE G-SERIES

SECTION 4-2

Approved by _____ Date _____ Approved by _____ Date _____



MODELS

Half Height Door Models: G12000, G12001

CLICK
TRANSFER
For KCL CADalog Website

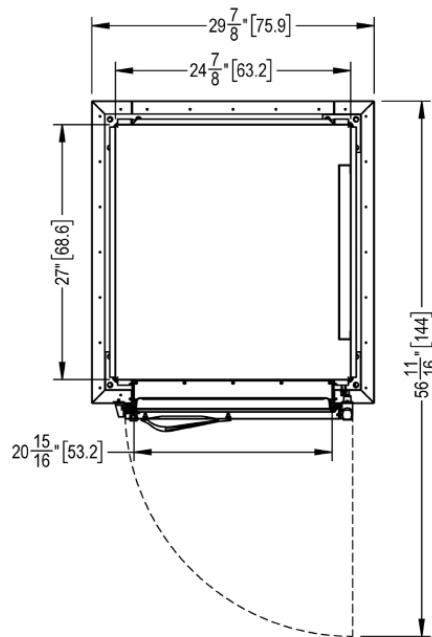
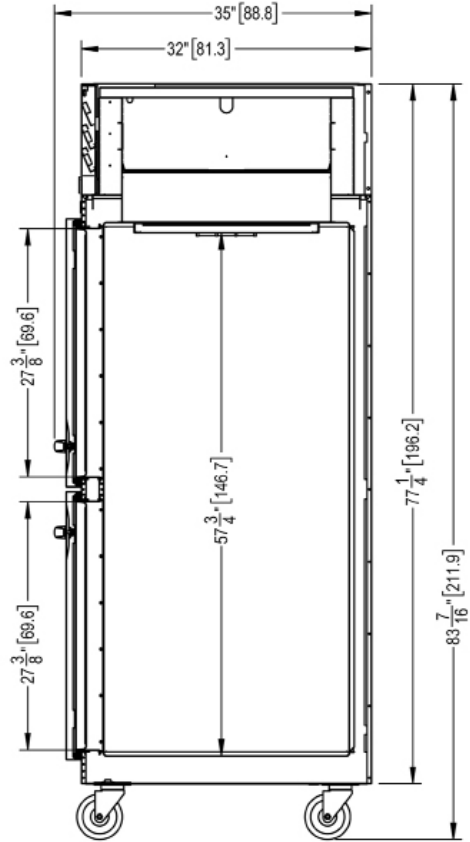
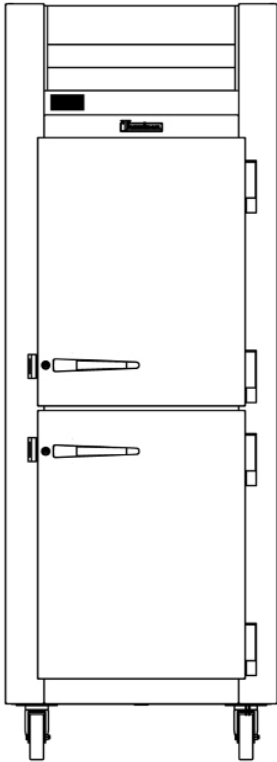

G-SERIES

1-Section Freezer Reach-In Self-Contained Solid Door(s)

MODELS

Full Height Door Models: G12010, G12011

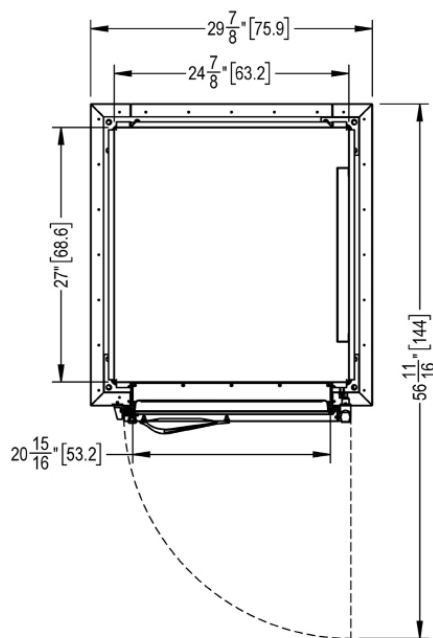
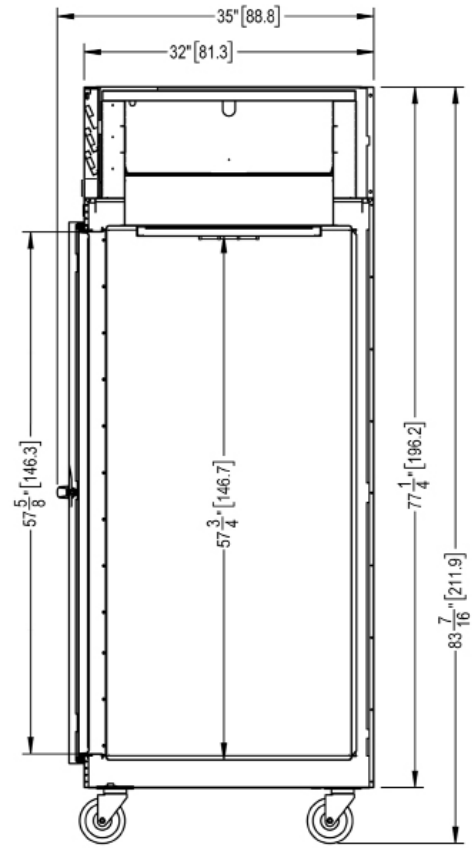
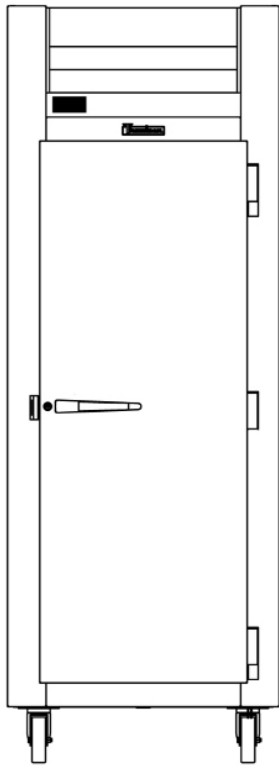



G-SERIES

1-Section Freezer Reach-In Self-Contained Solid Door(s)

MODELS

Half Height Door Models: G12000, G12001

Full Height Door Models: G12010, G12011

| MODELS | G120__ |
|---------------------------------------|---|
| DIMENSIONAL DATA | |
| Net Capacity cu. ft. ¹ | 23.37 [661.8 l] 23.43 [663.5 l] |
| L x D x H - Overall in. ² | 29 ⁷ / ₈ [75.9 cm] x 35 [88.8 cm] x 83 ⁷ / ₈ [211.9 cm] |
| Depth - over body in. | 32 [81.3 cm] |
| Depth - door open 90° in. | 57 ⁷ / ₈ [146.3 cm] |
| Clear half-door W x H in. | 21 ¹ / ₈ [53.6 cm] x 27 ¹ / ₂ [69.9 cm] |
| Clear full-door W X H in. | 21 ¹ / ₈ [53.6 cm] x 57 ⁷ / ₈ [146.3 cm] |
| No. Standard Shelves | 3 |
| Shelf Area sq. ft. ³ | 18.8 [1.75 sq m] |
| ELECTRICAL DATA | |
| Voltage Plug | 115/60/1 NEMA 5-15P [attached] |
| Feed wires with ground | 3 |
| Full Load Amperes MDEC ⁴ | 9.7 6.20 KWH/Day |
| REFRIGERATION DATA | |
| Refrigerant | R-448A |
| Refrigerant Charge oz. | 14 [396.9 g] |
| BTU/HR H.P. ⁵ | 1500 1/2 HP |
| Required Clearance | 12" Above |
| SHIPPING DATA | |
| L x D x H Crated in. | 48 [122 cm] x 42 [107 cm] x 85 [216 cm] |
| Volume Crated cu. ft. | 99 [2803 l] |

NOTES:

1. Net Capacity cu. ft. = Half Height Door | Full Height Door models.
2. Height shown when mounted on standard 6" high casters.
3. Figure shown reflects the area of standard shelf complement.
4. MDEC = Maximum Daily Energy Consumption
5. Based on a 90°F ambient and -20°F evaporator. For remote data please refer to spec sheet TR35837.

EQUIPMENT SPECIFICATIONS

CONSTRUCTION, HARDWARE, INSULATION

Cabinet exterior front, louver assembly and door(s) are constructed of 20 gauge stainless steel. Cabinet sides (including returns), interior and door liners are constructed of anodized aluminum. The exterior cabinet top, back and bottom are constructed of heavy gauge galvanized steel. A set of four (4) 6" high locking casters are included. Doors are equipped with a gasket protecting, raised metal door pan, cylinder locks, and guaranteed for life self-closing cam-lift hinges with a stay open feature at 120 degrees. Hinges include a concealed switch to automatically activate the interior LED lighting. Guaranteed for life, metal work flow door handles are mounted horizontally over recess in door which limits protrusion into aisle ways. Gasket profile and durable long life material simplify cleaning and increase overall gasket life. Anti condensate heaters are located behind each door opening. Both the cabinet and door(s) are insulated with an average of 2" thick high density, non-CFC, 100% foamed in place polyurethane.

SELF-CONTAINED REFRIGERATION SYSTEM

A top mounted, self-contained, balanced refrigeration system using environmentally friendly, non-flammable R-448A refrigerant is conveniently located behind the one piece louver assembly. It features an easy to clean front facing condenser, thermostatic expansion valve metering device, air-cooled hermetic compressor, large, high humidity evaporator coil located outside the food zone and a top mounted non-electric condensate evaporator. A 9' cord and plug is provided. Standard operating temperature is 0 to -5°F and can be adjusted to operate as low as -10°F in a 90°F or less ambient.

CONTROL

The easy to use water resistant microprocessor control is supplied standard. It includes a 3-Digit LED Display, and a Fahrenheit or Celsius Temperature Scale Display Capability.

INTERIOR ARRANGEMENTS

Standard interior arrangements include three (3) epoxy coated steel wire shelves, mounted on shelf pins, installed at the factory. Recommended load limit per shelf should not exceed 225 lbs.

DOMESTIC WARRANTY

Both a three year parts and labor warranty and an additional two year compressor parts warranty (for a total of five on self-contained models) are provided standard.

OPTIONAL ACCESSORY TRAY SLIDE VERSATILITY CHART

| TRAY SLIDE DRAWINGS | | | | | | |
|----------------------------|--|--|--|--|--|---|
| TRAY SLIDE OFFERING | #1 (1) 18" x26" or (2) 14"x18" | #4 (Rod Type) (1) 18" x26" | Universal (1) 18" x26" or (2) 14"x18" or (2) 12"x20" | #1 EZ-Change (1) 18" x26" or (2) 14"x18" | Universal EZ-Change (1) 18" x26" or (2) 14"x18" or (2) 12"x20" | HD Universal EZ-Change (1) 18" x26" or (2) 14"x18" or (2) 12"x20" |
| SPACING CAPACITY DOOR SIZE | 2" 28 Pairs Full Door & 13 Half 3" 19 Pairs Full Door & 09 Half 4" 14 Pairs Full Door & 07 Half 5" 11 Pairs Full Door & 05 Half | 1 1/2" 38 Pairs Full Door (2 Pair) 1 1/2" 18 Pairs Half Door (1 Pair) | 4" 14 Pairs Full Door & 06 Half ¹ 4" 14 Pairs Full Door & 07 Half ² 5" 11 Pairs Full Door & 05 Half 6" 09 Pairs Full Door & 04 Half | 2" 26 Pairs Full Door & 12 Half 4" 13 Pairs Full Door & 06 Half | 2 1/4" 22 Pairs Full Door & 11 Half 4 1/2" 11 Pairs Full Door & 05 Half | 4 1/2" 11 Pairs Full Door & 05 Half 9" 05 Pairs Full Door & 02 Half |

- Upper Half Height Door¹
- Lower Half Height Door²

CONTINUED PRODUCT DEVELOPMENT MAY NECESSITATE SPECIFICATION CHANGES WITHOUT NOTICE.