



Project _____
 AIA # _____ SIS # _____
 Item # _____ Quantity _____ C.S.I. Section 114000



DEALERS CHOICE G-SERIES

G-SERIES

1-Section Refrigerator Reach-In Self-Contained Solid Door(s)



STANDARD PRODUCT FEATURES

- High Performance, Energy Efficient Refrigeration System
- Reliable Microprocessor Control With LED Temperature Display
- Evaporator Coil Outside Food Zone Provides More Usable Space
- Load-Sure Guard Prevents Problems From Improper Loading
- Durable All Metal Construction
- Stainless Steel Front & Doors, Anodized Aluminum Sides & Interior
- Full or Half Height Door Models with a Variety of Hinging Configurations
- Long Life EZ Clean Door Gaskets
- Three (3) Epoxy Coated Shelves Per Section (factory installed)
- Easy to Maintain Front Facing Condenser Coil
- 6" High Locking Casters
- Guaranteed for Life Door Handles & Hinges
- 3-Year Parts & Labor Warranty
- 2-Years Additional Compressor Parts Warranty



Many models are ENERGY STAR® listed. Please refer to www.energystar.gov to view the most up-to-date product listing and performance data.



This unit is listed to the applicable UL, CSA and NSF Standards by an approved NRTL. Consult the factory or unit's data plate for approval information.

ACCESSORIES & OPTIONS (*field installed)

- ▣ Tray Slides for 18" x 26" Sheet Pans*
- ▣ Tray Slides for 12" x 20" Food Pans*
- ▣ Tray Slides for 14" x 18" Sheet Pans*
- ▣ Tray Slides for 18" x 26, 12" x 20" & 14" x 18" Pans*
- ▣ Additional Shelves*
- ▣ 6" High Legs*
- ▣ Lower Height Casters*
- ▣ Optional Remote Applications

*Please refer to form number TR35872 for precise kit details. See back page for tray slide versatility chart.

AVAILABLE CONFIGURATIONS

Half-Height Door Models

G10000	Hinging
G10001	Right
	Left

Full-Height Door Models

G10010	Hinging
G10011	Right
	Left

SECTION 4-1

Approved by _____ Date _____ Approved by _____ Date _____



MODELS

Half Height Door Models: G10000, G10001

CLICK
TRANSFER
For KCL CADalog Website

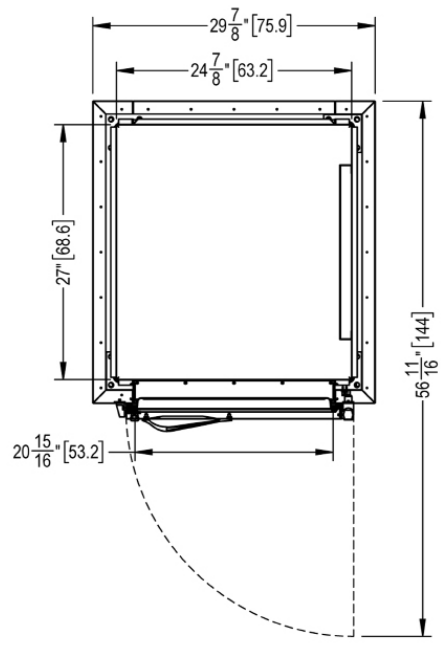
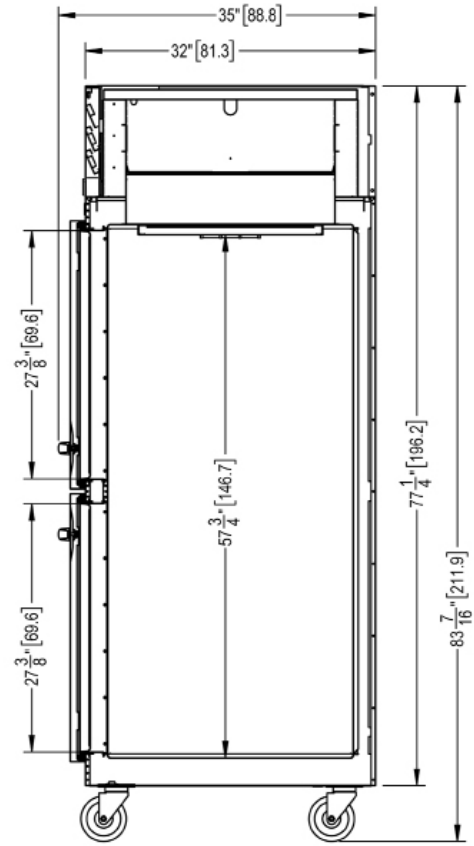
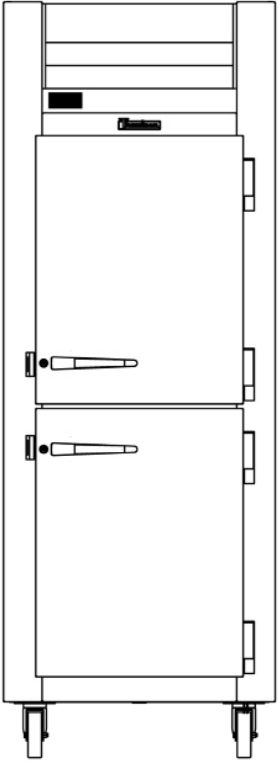

G-SERIES

1-Section Refrigerator Reach-In Self-Contained Solid Door(s)

MODELS

Full Height Door Models: G10010, G10011

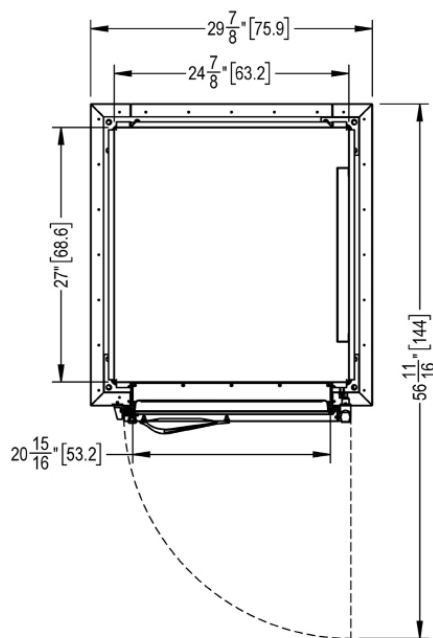
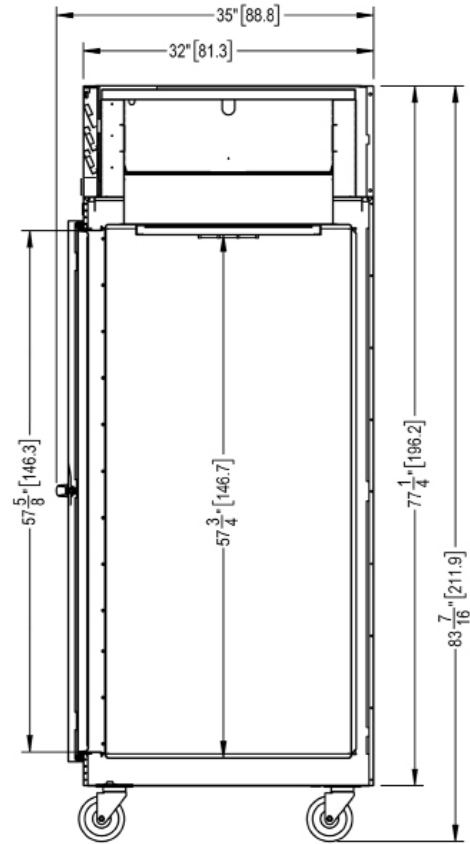
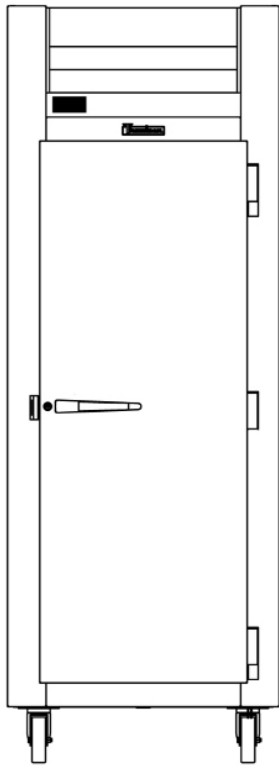



G-SERIES

1-Section Refrigerator Reach-In Self-Contained Solid Door(s)

MODELS

Half Height Door Models: **G10000, G10001**

Full Height Door Models: **G10010, G10011**

MODELS	G100__
DIMENSIONAL DATA	
Net Capacity cu. ft. ¹	23.37 (661.8 l) 23.43 (663.5 l)
L x D x H - Overall in. ²	29 ⁷ / ₈ (75.9 cm) x 35 (88.8 cm) x 83 ⁷ / ₈ (211.9 cm)
Depth - over body in.	32 (81.3 cm)
Depth - door open 90° in.	57 ⁷ / ₈ (146.3 cm)
Clear half-door W x H in.	21 ¹ / ₈ (53.6 cm) x 27 ¹ / ₂ (69.9 cm)
Clear full-door W X H in.	21 ¹ / ₈ (53.6 cm) x 57 ⁷ / ₈ (146.3 cm)
No. Standard Shelves	3
Shelf Area sq. ft. ³	18.8 (1.75 sq m)
ELECTRICAL DATA	
Voltage Plug	115/60/1 NEMA 5-15P (attached)
Feed wires with ground	3
Full Load Amperes MDEC ⁴	4.9 1.76 KWH/Day
REFRIGERATION DATA	
Refrigerant	R-450A
Refrigerant Charge Amount	16 oz
BTU/HR H.P. ⁵	1650 1/5 HP
Required Clearance	12" Above
SHIPPING DATA	
L x D x H Crated in.	48 (122 cm) x 42 (107 cm) x 85 (216cm)
Volume Crated cu. ft.	99 (2803 l)
Uncrated Crated Weight lbs.	305 (138 kg) 350 (150 kg)

NOTES:

1. Net Capacity cu. ft. = Half Height Door | Full Height Door models.
2. Height shown when mounted on standard 6" high casters.
3. Figure shown reflects the area of standard shelf complement.
4. MDEC = Maximum Daily Energy Consumption
5. Based on a 90°F ambient and 20°F evaporator. For remote data please refer to spec sheet TR35837.

EQUIPMENT SPECIFICATIONS

CONSTRUCTION, HARDWARE, INSULATION

Cabinet exterior front, louver assembly and door(s) are constructed of 20 gauge stainless steel. Cabinet sides (including returns), interior and door liners are constructed of anodized aluminum. The exterior cabinet top, back and bottom are constructed of heavy gauge galvanized steel. A set of four (4) 6" high locking casters are included. Doors are equipped with a gasket protecting, raised metal door pan, cylinder locks, and guaranteed for life self-closing cam-lift hinges with a stay open feature at 120 degrees. Hinges include a concealed switch to automatically activate the interior LED lighting. Guaranteed for life, metal work flow door handles are mounted horizontally over recess in door which limits protrusion into aisle ways. Gasket profile and durable long life material simplify cleaning and increase overall gasket life. Anti-condensate heaters are located behind each door opening. Both the cabinet and door(s) are insulated with an average of 2" thick high density, non-CFC, 100% foamed in place polyurethane.

SELF-CONTAINED REFRIGERATION SYSTEM

A top mounted, self-contained, balanced refrigeration system using environmentally friendly, non-flammable R-450A refrigerant is conveniently located behind the one piece louver assembly. It features an easy to clean front facing condenser, thermostatic expansion valve metering device, air-cooled hermetic compressor, large, high humidity evaporator coil located outside the food zone and a top mounted non-electric condensate evaporator. A 9' cord and plug is provided. Standard operating temperature is 34 to 38°F.

CONTROL

The easy to use water resistant microprocessor control is supplied standard. It includes a 3-Digit LED Display, and a Fahrenheit or Celsius Temperature Scale Display Capability.

INTERIOR ARRANGEMENTS

Standard interior arrangements include three (3) epoxy coated steel wire shelves, mounted on shelf pins, installed at the factory. Recommended load limit per shelf should not exceed 225 lbs.

DOMESTIC WARRANTY

Both a three year parts and labor warranty and an additional two year compressor parts warranty (for a total of five on self-contained models) are provided standard.

OPTIONAL ACCESSORY TRAY SLIDE VERSATILITY CHART

TRAY SLIDE DRAWINGS						
TRAY SLIDE OFFERING	#1 (1) 18" x26" or (2) 14"x18"	#4 (Rod Type) (1) 18" x26"	Universal (1) 18" x26" or (2) 14"x18" or (2) 12"x20"	#1 EZ-Change (1) 18" x26" or (2) 14"x18"	Universal EZ-Change (1) 18" x26" or (2) 14"x18" or (2) 12"x20"	HD Universal EZ-Change (1) 18" x26" or (2) 14"x18" or (2) 12"x20"
SPACING CAPACITY DOOR SIZE	2" 28 Pairs Full Door & 13 Half 3" 19 Pairs Full Door & 09 Half 4" 14 Pairs Full Door & 07 Half 5" 11 Pairs Full Door & 05 Half	1 1/2" 38 Pairs Full Door (2 Pair) 1 1/2" 18 Pairs Half Door (1 Pair)	4" 14 Pairs Full Door & 06 Half ¹ 4" 14 Pairs Full Door & 07 Half ² 5" 11 Pairs Full Door & 05 Half 6" 09 Pairs Full Door & 04 Half	2" 26 Pairs Full Door & 12 Half 4" 13 Pairs Full Door & 06 Half	2 1/4" 22 Pairs Full Door & 11 Half 4 1/2" 11 Pairs Full Door & 05 Half	4 1/2" 11 Pairs Full Door & 05 Half 9" 05 Pairs Full Door & 02 Half

- Upper Half Height Door¹
- Lower Half Height Door²

CONTINUED PRODUCT DEVELOPMENT MAY NECESSITATE SPECIFICATION CHANGES WITHOUT NOTICE.



REMOTE REFRIGERATION DATA

Refer to the chart below to determine the following remote characteristics: Voltage, Amps, BTU's and Refrigerant. The chart also indicates what components are included: Solenoid, Expansion Valve, and Temperature Control type.

MODEL NO	VOLTAGE	AMPS	BTU @ 90°F AMBIENT AND EVAP. TEMP.	REFRIG'T	SOLENOID YES/NO	EXP. VALVE YES/NO	TEMPERATURE CONTROL
G SERIES							
G10000, etc.	115/60/1	5.4	1520 @ +20°F Evap	R-407A	Yes	Yes	Microprocessor
G10002P, etc.	115/60/1	6.1	1520 @ +20°F Evap	R-407A	Yes	Yes	Microprocessor
G11000, etc.	115/60/1	5.4	2410 @ +20°F Evap	R-407A	Yes	Yes	Microprocessor
G11002P, etc.	115/60/1	6.1	2400 @ +20°F Evap	R-407A	Yes	Yes	Microprocessor
G12010, etc.	115/60/1	5.4	1930 @ -10°F Evap	R-407A	Yes	Yes	Microprocessor
G20000, etc.	115/60/1	6.1	2410 @ +20°F Evap	R-407A	Yes	Yes	Microprocessor
G20004P, etc.	115/60/1	7.5	2410 @ +20°F Evap	R-407A	Yes	Yes	Microprocessor
G21000, etc.	115/60/1	6.1	4160 @ +20°F Evap	R-407A	Yes	Yes	Microprocessor
G21004P, etc.	115/60/1	7.5	4160 @ +20°F Evap	R-407A	Yes	Yes	Microprocessor
G22010, etc.	115/60/1	8.2	3080 @ -10°F Evap	R-407A	Yes	Yes	Microprocessor
G30000, etc.	115/60/1	8.9	3780 @ +20°F Evap	R-407A	Yes	Yes	Microprocessor
G31010, etc.	115/60/1	8.9	4710 @ -10°F Evap	R-407A	Yes	Yes	Microprocessor
G31310, etc.	115/60/1	8.9	4710 @ -10°F Evap	R-407A	Yes	Yes	Microprocessor
G32000, etc.	115/60/1	8.9	5330 @ +20°F Evap	R-407A	Yes	Yes	Microprocessor
R/A SERIES							
R/AHT132W	115/60/1	5.4	2400 @ +20°F Evap	R-407A	Yes	Yes	Smart Control
R/AHT132E	115/60/1	5.4	2400 @ +20°F Evap	R-407A	Yes	Yes	Smart Control
R/AHT232W	115/60/1	5.4	4360 @ +20°F Evap	R-407A	Yes	Yes	Smart Control
R/AHT332W	115/60/1	5.4	4360 @ +20°F Evap	R-407A	Yes	Yes	Smart Control
R/AHT132N	115/60/1	5.4	2240 @ +20°F Evap	R-407A	Yes	Yes	Smart Control
R/AHT232N	115/60/1	5.4	4360 @ +20°F Evap	R-407A	Yes	Yes	Smart Control
R/AHT332N	115/60/1	5.4	4360 @ +20°F Evap	R-407A	Yes	Yes	Smart Control
R/AHT126W	115/60/1	5.4	2400 @ +20°F Evap	R-407A	Yes	Yes	Smart Control
R/AHT226W	115/60/1	5.4	2400 @ +20°F Evap	R-407A	Yes	Yes	Smart Control
R/AHT132D	115/60/1	5.4	2400 @ +20°F Evap	R-407A	Yes	Yes	Smart Control
R/AHT232D	115/60/1	5.4	4360 @ +20°F Evap	R-407A	Yes	Yes	Smart Control
R/AHT132WP	115/60/1	5.4	2400 @ +20°F Evap	R-407A	Yes	Yes	Smart Control
R/AHT232WP	115/60/1	5.4	4360 @ +20°F Evap	R-407A	Yes	Yes	Smart Control
R/AHT332WP	115/60/1	5.4	4360 @ +20°F Evap	R-407A	Yes	Yes	Smart Control
R/ALT132N	115/60/1	5.4	1930 @ -20°F Evap	R-407A	Yes	Yes	Smart Control
R/AHT232NP	115/60/1	5.4	4360 @ +20°F Evap	R-407A	Yes	Yes	Smart Control
R/AHT332NP	115/60/1	5.4	4360 @ +20°F Evap	R-407A	Yes	Yes	Smart Control
R/AHT126WP	115/60/1	5.4	2400 @ +20°F Evap	R-407A	Yes	Yes	Smart Control
R/AHT226WP	115/60/1	5.4	2400 @ +20°F Evap	R-407A	Yes	Yes	Smart Control
R/ALT132W	115/60/1	5.4	2160 @ -20°F Evap	R-407A	Yes	Yes	Smart Control
R/ALT232W	115/60/1	5.4	3790 @ -20°F Evap	R-407A	Yes	Yes	Smart Control
R/ALT332W	115/60/1	5.4	5220 @ -20°F Evap	R-407A	Yes	Yes	Smart Control
R/ALT132N	115/60/1	5.4	1930 @ -20°F Evap	R-407A	Yes	Yes	Smart Control
R/ALT232N	115/60/1	5.4	3790 @ -20°F Evap	R-407A	Yes	Yes	Smart Control
R/ALT332N	115/60/1	5.4	5220 @ -20°F Evap	R-407A	Yes	Yes	Smart Control
R/ALT126W	115/60/1	5.4	1980 @ -20°F Evap	R-407A	Yes	Yes	Smart Control
R/ALT226W	115/60/1	5.4	3790 @ -20°F Evap	R-407A	Yes	Yes	Smart Control
R/ALT132D	115/60/1	5.4	2160 @ -20°F Evap	R-407A	Yes	Yes	Smart Control
R/ALT232D	115/60/1	5.4	3790 @ -20°F Evap	R-407A	Yes	Yes	Smart Control
R/ARI132L	115/60/1	5.4	2400 @ +20°F Evap	R-407A	Yes	Yes	Smart Control
R/ARI232L	115/60/1	5.4	4360 @ +20°F Evap	R-407A	Yes	Yes	Smart Control
R/ARI332L	115/60/1	5.4	5330 @ +20°F Evap	R-407A	Yes	Yes	Smart Control
R/ARI132LP	115/60/1	5.4	2400 @ +20°F Evap	R-407A	Yes	Yes	Smart Control
R/ARI232LP	115/60/1	5.4	4360 @ +20°F Evap	R-407A	Yes	Yes	Smart Control
R/ARI332LP	115/60/1	5.4	5330 @ +20°F Evap	R-407A	Yes	Yes	Smart Control



REMOTE REFRIGERATION DATA

MODEL NO	VOLTAGE	AMPS	BTU @ 90°F AMBIENT AND EVAP. TEMP.	REFRIG'T	SOLENOID YES/NO	EXP. VALVE YES/NO	TEMPERATURE CONTROL
R/A Series (Cont'd)							
R/ARI132H	115/60/1	5.4	2400 @ +20°F Evap	R-407A	Yes	Yes	Smart Control
R/ARI232H	115/60/1	5.4	4360 @ +20°F Evap	R-407A	Yes	Yes	Smart Control
R/ARI332H	115/60/1	5.4	5330 @ +20°F Evap	R-407A	Yes	Yes	Smart Control
R/AIF132L	115/60/1	5.4	2160 @ -20°F Evap	R-407A	Yes	Yes	Smart Control
R/AIF232L	115/60/1	5.4	5220 @ -20°F Evap	R-407A	Yes	Yes	Smart Control
R/AIF332L	115/60/1	5.4	7580 @ -20°F Evap	R-407A	Yes	Yes	Smart Control
R/ACV132W	115/60/1	5.4	2160 @ -10°F Evap	R-407A	Yes	Yes	Smart Control
R/ACV232W	115/60/1	5.4	1870 @ -10°F Evap	R-407A	Yes	Yes	Smart Control
TE036HR	115/60/1	5.4	2370 @ +20°F Evap	R-407A	Yes	Yes	Microprocessor
TE048HR	115/60/1	5.4	2370 @ +20°F Evap	R-407A	Yes	Yes	Microprocessor
TE060HR	115/60/1	5.4	2370 @ +20°F Evap	R-407A	Yes	Yes	Microprocessor
TE072HR	115/60/1	5.4	2370 @ +20°F Evap	R-407A	Yes	Yes	Microprocessor
TE084HR	115/60/1	5.4	2370 @ +20°F Evap	R-407A	Yes	Yes	Microprocessor
TE096HR	115/60/1	5.4	4090 @ +20°F Evap	R-407A	Yes	Yes	Microprocessor
TE110HR	115/60/1	5.4	4090 @ +20°F Evap	R-407A	Yes	Yes	Microprocessor
TU Series							
TU044HR	115/60/1	3.3	3080 @ +20°F Evap	R-407A	Yes	Yes	Microprocessor
TU072HR	115/60/1	3.7	3080 @ +20°F Evap	R-407A	Yes	Yes	Microprocessor
TU100HR	115/60/1	3.9	3080 @ +20°F Evap	R-407A	Yes	Yes	Microprocessor
TS Series							
TS048HR	115/60/1	7.2	3300 @ +10°F Evap	R-407A	Yes	Yes	Microprocessor
TS066HR	115/60/1	7.2	3870 @ +10°F Evap	R-407A	Yes	Yes	Microprocessor
TS072HR	115/60/1	7.7	3870 @ +10°F Evap	R-407A	Yes	Yes	Microprocessor
TS090HR	115/60/1	7.7	3870 @ +10°F Evap	R-407A	Yes	Yes	Microprocessor

NOTES:

- Remote microprocessor and smart control equipped units do not require use of a temperature control.
- Cord and plug are not supplied with remote units.
- Listed BTU rating shown is the required BTU's delivered to the unit at the evaporator coil.
- Compressor HP not supplied by Traulsen. Compressor size should be determined by a qualified refrigeration technician based on the delivered BTU rating at the unit and actual jobsite requirements.
- To determine approximate remote model weights, please deduct 40 lbs. from the respective self-contained models net or gross weight.
- Standard Traulsen five year compressor warranty does not apply to remote units.
- Condensate Removal: All remote models require provisions to be made to allow for condensate removal by the operator. As supplied standard, these models include only a drain tube exiting evaporator compartment on top of the cabinet from which condensate will drip. Optional condensate removal provisions include a drain line extended down the cabinet back (n/a for pass-thru or roll-thru models) or Top-Mounted Condensate Evaporator, all supplied by others.
Note: Provision of the first option will add approximately 7/8" to the overall cabinet depth.
- Traulsen does not recommend the use of casters with remote models (legs supplied standard on G-Series remote units).
- Refrigeration connections provided are 1/4" O.D. for the liquid line and either 1/2" or 3/4" O.D. for the suction line, no other connections are required.
- The solenoid valve provided is wired at the factory directly to the control, therefore no electrical connections are required between the unit and remote compressor.
- For optional refrigerant options consult with factory at time of order to ensure correct expansion valve is provided.

CONTINUED PRODUCT DEVELOPMENT MAY NECESSITATE SPECIFICATION CHANGES WITHOUT NOTICE.