



RFS-1279R Low-Side/Rack Flake Ice Machine

Model

RFS-1279R



RFS-1279R Low-Side/Rack Flake Ice Machine on B-570 Bin

Standard Features

A Low-side/Rack Flake Ice Machine System consists of ice machine head section, ice storage unit, and interconnecting refrigerant lines—all ordered separately which connect into the store supplied centralized condensing system often called a rack. The rack system is shared by a variety of low side refrigeration equipment within the store like refrigerated food and beverage display cases and glass door freezer displays.

- Up to 1092 lbs (495 kg) daily ice production.
- Only 22" (55.88 cm) wide.
- Evaporator is designed for maximum quality and operating life.
- Flake Ice is perfect for food display, salad bars and cold therapy/healthcare.
- Ice forms around object without bruising and holds objects in place without tipping/spilling.
- Noise is removed from the ice making area promoting a relaxing atmosphere.
- Ice machine is lighter in weight to simplify installation.
- Stainless steel exterior has a clean and modern look to enhance the display in any self-serve environment.

Ice Shape

Flake ice is small hard bits of ice ideally suited for presentation applications.





RFS-1279R Ice Machine

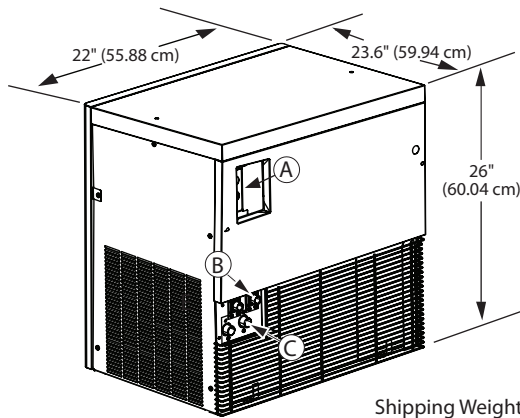

Shipping Weight:
186 lbs / 84.5 kg

- (A) Electrical Entrance (2) Options
- (B) 3/8" F.P.T. Ice Making Water Inlet
- (C) 1/2" M.P.T. Ice Making Water Drain

Bin	Adapter
B-570	K-00404*
B-970	K-00405
F-700	K-302500
F-1300	K-482500
F-1325	K-602500
FC-1350	K-612500

* K-00404 included standard with purchase of RF-1278C flake ice machine

Ice Machine Electric

208-230/60/1, 50 Hz version also available

Minimum circuit ampacity: 1.4

Max. fuse size: 15 amps

HACR-type circuit breakers can be used in place of fuses.

Specifications

Refrigerant: R404A and R507

Refrigerating Capacity: 7100 BTUH

Operating Limits:

- Ambient Temperature Range: 50°-110°F (10°-43°C)
- Water Temperature Range: 37°-90°F (3°-32°C)
- Water Pressure Ice Maker Water In: Min. 14 psi (96.5 kPa) Max. 80 psi (551.1 kPa)

Installation Information and Dimensions:

- Maximum Line Length— 100' (30.5 m)*
- Maximum Vertical Rise*— 35' (10.7 m) above ice machine.
- Maximum Vertical Drop— 15' (4.5 m) below ice machine.

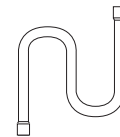

*A rise over 20' (6 m) requires S-Trap Kit K-00172 - ordered separately

Low-Side Rack Ice Machine

Model	Ice Shape	Ice Production 24 Hours*		Power Usage kWh/100 lbs@ 90°Air/70°F 32°Air/21°C Water	Potable Water Usage/100 lbs 45.4 kg of Ice
		70°Air/ 50°F Water 21°Air/ 10°C Water	90°Air/ 70°F Water 32°Air/ 21°C Water		
RFS-1279R	Flake	1092 lbs	958 lbs	1.50	12 Gal.
		495 kg	435 kg		45 L

* ice production based on 404A refrigerant
Order ice storage bin separately. Will not accept AuCS accessory.

Standard Interconnecting Tubing

Model	Line Length		Weight	
	ft.	m	lbs	kg
RC-21	20	6	12	5
RC-31	30	9	20	9
RC-51	50	15	28	13

