



# QuietQube® RFS-1278C Remote Flake Ice Machine

## Models

- RFS-1278C



RFS-1278C Remote Flake Ice Machine - 208-230V



RCU -1075 Condensing Unit - 208-230V



RFS-1278C Remote Flake Ice Machine on B-570 Bin

## Standard Features

QuietQube® Series Remote System consists of a remote condensing unit, interconnecting refrigerant lines, ice machine head section, and ice storage unit—All ordered separately. QuietQube ice machine with RCU condensing unit is designed as a Manitowoc system and not for use with any other ice machine or remote condenser brand.

- Up to 1092 lbs (495 kg) daily ice production.
- Only 22" (55.88 cm) wide.
- Evaporator is designed for maximum quality and operating life.
- Remote, air-cooled condenser system improves efficiency and ice production, conserving energy. Manitowoc remote condenser systems effectively dissipate heat at a convenient location, indoors or outdoors, away from the ice machine. This maximizes ice-making capability and minimizes air conditioning loads by lowering the ambient air temperature at the ice machine.
- Quiet operation eliminates most noise from the refrigeration system. Promotes a relaxing atmosphere.
- Ice machine is lighter in weight to simplify installation.
- Stainless steel exterior has a clean and modern look to enhance the display in any self-serve environment.

## Warranty

- 3-year Parts.
- 2-year Labor.
- Compressor parts for 5 years and labor for 2 years.

## Ice Shape

Flake ice is small hard bits of ice ideally suited for presentation applications.





### RFS-1278C Ice Machine

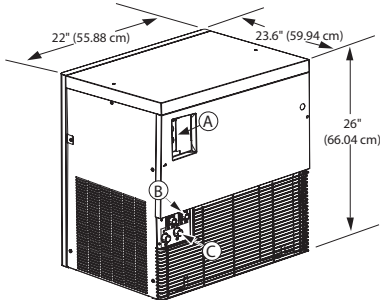

Shipping Weight: 186 lbs / 84.5 kg

### Ice Machine Electric

208-230/60/1, 50 Hz version also available.

Minimum circuit ampacity: 1.4

Max. fuse size: 15 amps

The ice machine and condensing unit are powered independently of each other. HACR-type circuit breakers can be used in place of fuses.

- Ⓐ Electrical Entrance (2) Options
- Ⓑ 3/8" F.P.T. Ice Making Water Inlet
- Ⓒ 1/2" M.P.T. Ice Making Water Drain

### Specifications

Refrigerant: R404A

#### Operating Limits:

- Ambient Temperature Range: 50°-110°F (10°-43°C)
- Water Temperature Range: 37°-90°F (3°-32°C)
- Water Pressure Ice Maker Water In: Min. 14 psi (96.5 kPa) Max. 80 psi (551.1 kPa)

Bin	Adapter
B-570	K-00404*
B-970	K-00405
F-700	K-302500
F-1300	K-482500
F-1325	K-602500
FC-1350	K-612500

\* K-00404 included standard with purchase of RFS-1278C flake ice machine

### RCU-1075 Condensing Unit

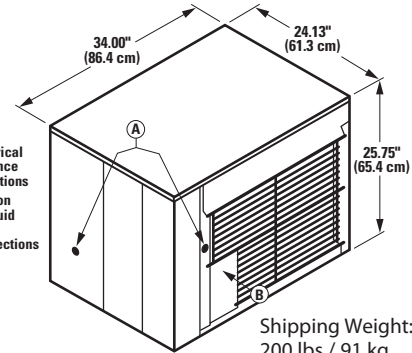

Shipping Weight: 200 lbs / 91 kg

- Ⓐ Electrical Entrance (2) Options
- Ⓑ Suction & Liquid Line Connections

### Condensing Unit Electric

**208-230/60/1 standard.** 208-230/60/3 also available. **Note:** QuietQube ice machine is wired independent of condensing unit.

Min. circuit ampacity: 15 1ph 15 3ph

Max. fuse size: 15 1ph 15 3ph

BTU Per Hour: 7,680 (average)

Compressor: Nominal rating: 1-1/2 HP

#### Operating Limits:

Ambient Temperature Range: -20° to 120°F (-29° to 49°C)

#### Installation Information and Dimensions:

Maximum Line Length—

100' (30.5 m)\*

Maximum Vertical Rise\*—

35' (10.7 m) above ice machine.

Maximum Vertical Drop—

15' (4.5 m) below ice machine.

\*A rise over 20' (6 m) requires S-Trap Kit K-00172 - ordered separately

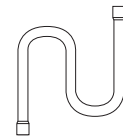

### Remote Air-cooled Ice Machine

Model	Ice Shape	Ice Production 24 Hours		Power Usage kWh/100 lbs. @ 90° Air/70°F 32° Air/21°C Water	Potable Water Usage/ 100 lbs. 45.4 kgs of Ice
		70° Air/ 50°F Water 21° Air/ 10°C Water	90° Air/ 70°F Water 32° Air/ 21°C Water		
RFS-1278C	Flake	1092 lbs 495 kg	958 lbs. 435 kg	3.98	12 Gal. 45 L

Order ice storage bin separately. Will not accept AuCS accessory.

### Standard Interconnecting Tubing

Model	Line Length		Weight	
	ft	m	lbs	kg
RC-21	20	6	12	5
RC-31	30	9	20	9
RC-51	50	15	28	13

