



# QuietQube® RN-1278C Remote Nugget Ice Machine

## Models

RN-1278C



RN-1278C Remote Nugget Ice Machine - 115V



RCU Condensing Unit - 208-230V



RN-1278C Remote Nugget Ice Machine on B-570 Bin



RN-1278C Remote Nugget Ice Machine on Servend SV-250 Dispenser

## Standard Features

QuietQube® Series Remote System consists of a remote condensing unit, interconnecting refrigerant lines, ice machine head section, and ice storage unit— whether storage bin, countertop or floor-standing dispenser. All ordered separately. QuietQube ice machine with RCU condensing unit is designed as a Manitowoc system and not for use with any other ice machine or remote condenser brand.

- Up to 1,106 lbs. (502 kgs.) daily ice production.
- Only 22" (55.88 cm) wide.
- Evaporator is designed for maximum quality and operating life.
- Quiet operation eliminates most noise from the refrigeration system. Promotes a relaxing atmosphere.
- Ice machine is lighter in weight and 115 volt simplifies installation.
- Stainless steel exterior has a clean and modern look to enhance the display in any self-serve environment.

## Warranty

- 3-year Parts.
- 2-year Labor.
- Compressor parts for 5 years and labor for 2 years.

## Ice Shape

- Nugget Ice provides a softer, chewable texture while still providing maximum cooling effect.
- 5/8" (1.59 cm) diameter cylindrical-shaped nugget with average length of approximately 1" (2.54 cm).





### RN-1278C Ice Machine

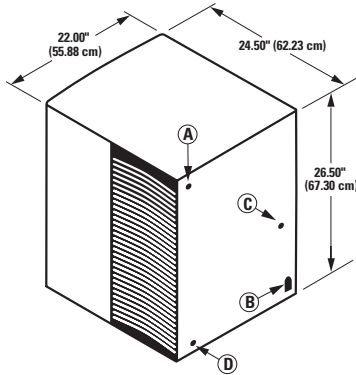

Shipping Weight: 201 lbs. / 91 kgs.

- Ⓐ 3/8" F.P.T. Ice Making Water Inlet
- Ⓑ Refrigerant Lines
- Ⓒ Electrical Entrance
- Ⓓ 3/4" M.P.T. Drain Fitting

**Dispenser Note** - Verify with the dispenser manufacturer that the correct agitator and deflector kit for nugget ice dispensing is included with your dispenser purchase.

### Ice Machine Electric

115/60/1 ice machines are factory pre-wired with a 7' (2m) power cord and NEMA 5-15 right angle plug configuration.

**Total Amps:** 6.0

**Max. fuse size:** 15 amps

The ice machine and condensing unit are powered independently of each other.

### Specifications

**Refrigerant:** R404A

#### Operating Limits:

- Ambient Temperature Range: 50°-100°F (14.4°-37.8°C)
- Water Temperature Range: 45°-90°F (7.2°-32.2°C)
- Water Pressure Ice Maker Water In: Min. 20 psi (137.9 kPA) Max. 70 psi (483 kPA)

### RCU-1275 Condensing Unit

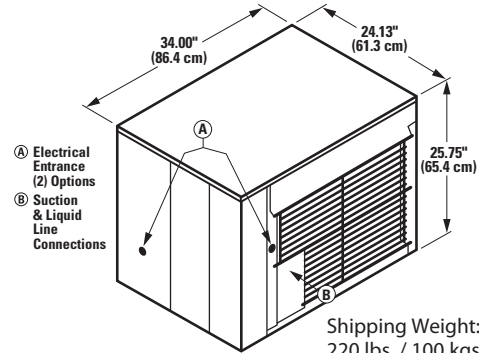

Shipping Weight: 220 lbs. / 100 kgs.

### Condensing Unit Electric

**208-230/60/1 standard.** 208-230/60/3 also available. **Note:** QuietQube ice machine is wired independent of condensing unit.

**Min. circuit ampacity:** 15 1ph 15 3ph

**Max. fuse size:** 15 1ph 15 3ph

**BTU Per Hour:** 14,400 (average)

**Compressor:** Nominal rating: 2 HP

#### Operating Limits:

Ambient Temperature Range: -20° to 120°F (-29° to 49°C)

#### Installation Information and Dimensions:

Maximum Line Length—100' (30.5 m)\*

Maximum Vertical Rise\*—35' (10.7 m) above ice machine.

Maximum Vertical Drop—15' (4.5 m) below ice machine.

\*A rise over 20' (6 m) requires S-Trap Kit K-00172 - ordered separately

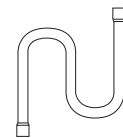

### Remote Air-cooled Ice Machine

Model	Ice Shape	Ice Production 24 Hours		Power Usage kWh/100 lbs. @ 90° Air/70°F Water	Potable Water Usage/ 100 lbs. 45.4 kgs. of Ice
		70° Air/ 50°F Water	90° Air/ 70°F Water		
RN-1278C	Nugget	1106 lbs.	964 lbs.	4.92	13.2 Gal.
		502 kgs.	437 kgs.		

Order ice storage bin separately. Will not accept AuCS accessory.

### Standard Interconnecting Tubing

Model	Line Length		Weight	
	ft.	m.	lbs.	kgs.
RC-21	20	6	12	5
RC-31	30	9	20	9
RC-51	50	15	28	13