



RN-400 Tubular Nugget Ice Machine

Models

RN-0408A



RN-0408A Nugget Ice Machine on Servend SV-250 Dispenser

RN-0408A Nugget Ice Machine on B-420 Bin

Standard Features

- Up to 385 lbs. (175 kgs) daily ice production.
- Only 22" (55.9 cm) wide.
- Perfect for beverage applications, dispensing and cold therapy.
- Evaporator is designed for maximum quality and operating life.
- 90% ice to water ratio and longer pieces makes tubular nugget ideal for dispensing without congealing.
- Great for blended drinks with less wear on blender and smoother texture.
- Optional 9" discharge tube ships in carton for dispense applications.

COMMERCIAL WARRANTY		
ICE MAKER	COMPRESSOR	
3	2	5
YEAR PARTS	YEAR LABOR	YEAR PARTS 2 YEAR LABOR

Specifications

BTU Per Hour: 5,000
 Compressor:
 Nominal rating: 1/2 HP
 Refrigerant: R404A

Operating Limits:

- Ambient Temperature Range: 50°-100°F (10.0°C-37.8°C)
- Water Temperature Range: 45°-90°F (7.2°-32.2°C)
- Water Pressure Ice Maker Water In:
 Min. 20 psi (137.9 kPa)
 Max. 70 psi (483 kPa)

Ice Machine Electric

115/60/1 ice machines are factory pre-wired with a 7' (2m) power cord and NEMA 5-20 right angle plug configuration.

Total Amps: 11 amps

Maximum fuse size: 20 amps

Ice Shape

- Tubular Nugget Ice provides a softer, chewable texture while still providing maximum cooling effect.
- 5/8" (1.59 cm) diameter cylindrical-shaped nugget with average length of approximately 1" (2.54 cm).





RN-400 Tubular Nugget Ice Machine

RN-400 on B-420 Storage Bin

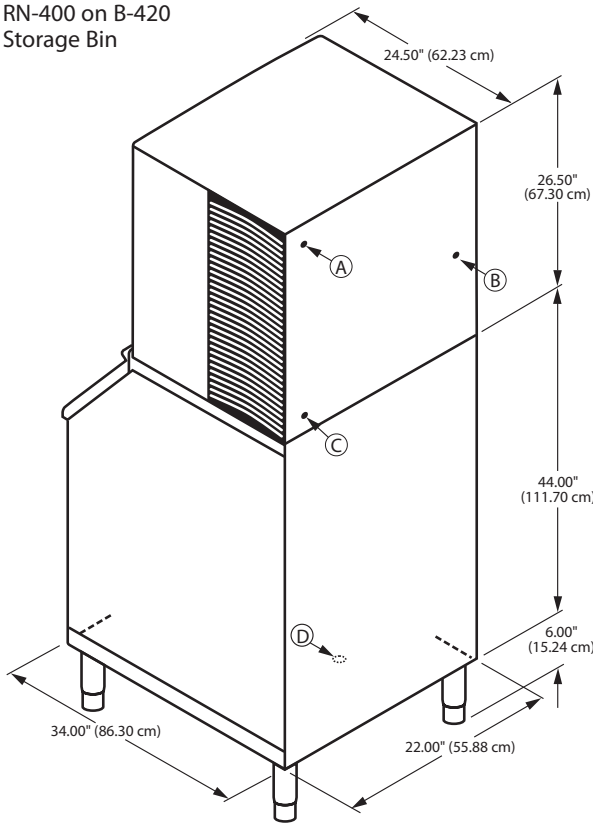

- (A) 3/8" F.P.T. Ice Making Water Inlet (C) 3/4" M.P.T. Ice Making Water Drain
- (B) Electrical Entrance (D) 3/4" Bin Drain

Installation Note -

Minimum installation clearance: Top/sides: 8" (20.32 cm), back: 5" (12.7 cm).

Dispenser Note -

Verify with the dispenser manufacturer that the correct agitator and deflector kit for nugget ice dispensing is included with your dispenser purchase.

Space Saving Designs



	RN-400 B-320	RN-400 B-420
Height	64.50" 168.83 cm	76.50" 194.3 cm
Width	22.00" 55.88 cm	22.00" 55.88 cm
Depth	34.00" 86.30 cm	34.00" 86.30 cm
Bin Storage	210 lbs. 95 kgs	310 lbs. 141 kgs

Height includes adjustable bin legs 6.00" to 7.00", (15.24 to 17.78 cm) set at 6.00" (15.24 cm).

Air Flow Top View

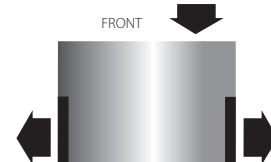

Specifications

	Model	Ice Shape	Ice Production 24 Hours		Power Usage kWh/100 lbs.@90°Air/70°F	Potable Water Usage/ 100 lbs. 45.4 kgs of Ice
			70°Air/ 50°F Water	90°Air/ 70°F Water		
AIR-COOLED	RN-0408A	Nugget	385 lbs.	294 lbs.	6.38	12.6 Gal.
			175 kgs	133 kgs		47.7 L

Order ice storage bin separately. *A" following model number indicates "Air" condensing unit. Will not accept AuCS accessory.