

QuietQube® i-686C Remote Ice Cube Machine

Air-Cooled Ice Cube Machine with Patented CVD Technology®

Model

- ID-0686C IY-0686C



ID-0686C Ice Cube Machine - 115V

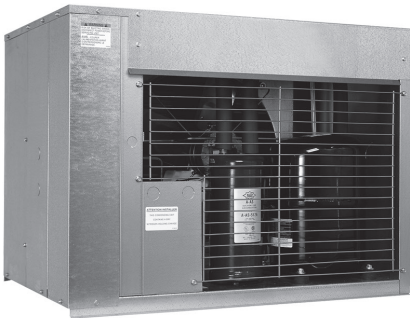

CVD Condensing Unit - 230V



ID-0686C Ice Machine on a B-570 Bin

QuietQube Series Remote System consists of a remote condensing unit, interconnecting refrigerant lines, ice machine head section along with an ice storage bin, countertop dispenser, or floor dispenser. All ordered separately. QuietQube ice machine with CVD condensing unit is designed as a Manitowoc system and cannot be used with any other ice machine or remote condenser brand.

- **New Levels of Performance** – showcasing improved ambient ice production along with reductions in energy consumption: 10% Reduction in energy and 5% improvement in production on a weighted average basis for the i-600 series.
- **ENERGY STAR** – the i-600s exceed ENERGY STAR™ standards and targets future energy efficiency standards.
- **Space-Saving Design** – Up to 634 lbs. (288 kgs) daily ice production and only 30" (76.20 cm) wide.
- **Intelligent Diagnostics** – provide 24 hour preventative maintenance and diagnostic feedback for trouble free operation.
- **Acoustical Ice Sensing Probe** – for reliable operation in challenging water conditions.
- **EasyRead Display** – communicates operating status, cleaning reminders, and asset information through a blue illuminated display.
- **Programmable Ice Production** – by On/Off Time, Ice Volume or Bin Level (with accessory bin level control) further improves energy efficiency and savings.
- **Easy to Clean Foodzone** – Removable water-trough, distribution tube, splash shield, and sensing probes for fast and efficient cleaning. Select components made with AlphaSan® antimicrobial.
- **DuraTech™ Exterior** – provides superior corrosion resistance. Stainless finish with innovative clear-coat resists fingerprints and dirt.
- Available **LuminIce™ Growth Inhibitor** controls the growth of bacteria and yeast within the foodzone.



Ice Shape



Half Dice
 $\frac{3}{8}$ " x $\frac{1}{8}$ " x $\frac{7}{8}$ "
 (.95 x 2.86 x 2.22 cm)



Dice
 $\frac{7}{8}$ " x $\frac{7}{8}$ " x $\frac{7}{8}$ "
 (2.22 x 2.22 x 2.22 cm)





i-686C Ice Machine

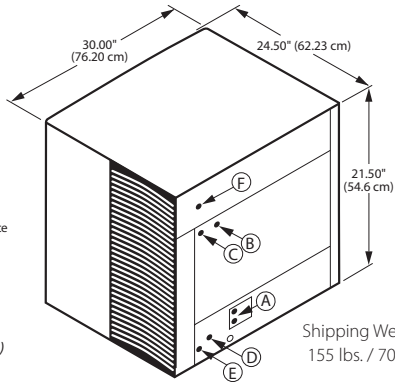

- (A) Electrical Entrance (2) Options
- (B) Suction Refrigerant Shut-off Valve
- (C) Liquid Refrigerant Shut-off Valve
- (D) 3/8" (0.95 cm) F.P.T. Ice Making Water Inlet
- (E) 1/2" (1.27 cm) F.P.T. Ice Making Water Drain
- (F) Communicator Cable Entrance

Installation Note

Minimum installation clearance:

Top/Sides/Back: 5" (13 cm)

Shipping Weight: 155 lbs. / 70 kgs

Specifications

Operating Limits:

- Ambient Temperature Range: 35° to 110°F (1.7° to 43.3°C)
- Water Temperature Range: 35° to 90°F (1.7° to 32.2°C)
- Water Pressure Ice Maker Water In: Min. 20 psi (137.9 kPa) Max. 80 psi (551.1 kPa)

Ice Machine Electric

115/60/1 standard. (230/50/1 also available, consult factory.)
Total Amps: 1.1
Max. fuse size: 15 amps
 HACR-type circuit breakers can be used in place of fuses.

iAuCS® Accessory

Schedules and performs routine ice machine cleaning automatically.



iCVD-0696 Remote Condensing Unit

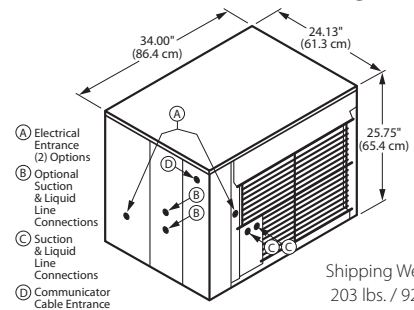

Shipping Weight: 203 lbs. / 92 kgs

Condensing Unit Electric

208-230/60/1 standard. 208-230/60/3 and 230/50/1 also available. 50 Hz version of this model meets the international standard, IEC335-1, requirements for "tropical rating," the most severe duty rating an ice machine can obtain, (consult factory). HACR-type circuit breakers can be used in place of fuses.
Note: QuietQube ice machine power supply is wired independent of CVD condensing unit.

Min. circuit ampacity:
 11.6 1ph 10.2 3ph

Max. fuse size:
 15 amps 1ph 15 amps 3ph
 HACR-type circuit breakers can be used in place of fuses.

BTU Per Hour:
 11,800 (average) 13,700 (peak)

Compressor:
 Nominal rating: 1 HP

Operating Limits:

- Ambient Temperature Range: -20° to 130°F (-29° to 54°C)

Installation Information and Dimensions:

Maximum Line Length
 —100' (30.5 m).*

Maximum Vertical Rise*
 —35' (10.7 m) above ice machine.

Maximum Vertical Drop
 —15' (4.5 m) below ice machine.

*A rise over 20' (6 m) requires S-Trap Kit K-00172 - ordered separately.

Minimum Installation Clearance:
 —Top/Sides: 0" (0 cm) Back/Front: 48" (122 cm).

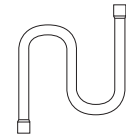

Interconnecting Tubing with Required Communication Wire*

Communication wire comes with each of the following line sets

Model	Line Length		Weight	
	ft.	m	lbs.	kgs
RC-26	20	6	12	5
RC-36	30	9	20	9
RC-56	50	15	28	13

*When using a non-Manitowoc line-set, a 186A 5-conductor communication cable must be installed between the head and condenser sections (K-00435).

Remote Air-cooled Ice Machine

Model	Ice Shape	Ice Production 24 Hours		Power kWh/100 lbs* @ 90°/70°F	ENERGY STAR
		70° Air/50°F Water 21° Air/10°C Water	90° Air/70°F Water 32° Air/21°C Water		
ID-0686C	dice	607 lbs.	520 lbs.	5.57	★
		275 kgs	236 kgs		
IY-0686C	half-dice	634 lbs.	530 lbs.	5.54	★
		288 kgs	240 kgs		
Water usage/100 lbs./45.4 kgs of Ice					
Potable Water: 20 gallons, 75.7 liters					

Ice machine for use with ice storage bin or ice dispenser and ICVD condensing unit all ordered separately.

*kWh per 100 lbs. is total power of ice machine and condensing unit. Ice machine is 1 ph only. Condensing unit is 1 ph or 3 ph.