



# SMARTSTEAM100 BOILERLESS STEAMER

## MODEL (2)SSB-10GF

Steamer shall be a Groen Model (2)SSB-10GF SmartSteam100™ stainless steel, boilerless, convection steamer. Each steamer cavity shall have a self-contained atmospheric 100,000 BTU/hr gas steam generating reservoir.

**CONSTRUCTION:** Steamer cavity, cabinet and stand shall be all stainless steel construction, with removable right and left-side panels, providing access to internal components. Steamer shall have no side vents for increased water/spray resistance. Steamer cavities shall accommodate 18 x 26" bake pans. Steamer doors shall be all stainless steel with a strong continuous hinge and field-reversible for left or right swing. Doors shall be insulated and provided with a one-piece, replaceable seal. Hands free door handles and latches shall provide positive lock and seal when doors are pushed or slammed shut. A hidden magnetic door switch shall cut power to blower fan and shut down power to the steam generating reservoir when a door is opened. Pan support racks shall be stainless steel and removable for easy cleaning. A stainless steel condensate collection tray shall be positioned under each cavity door.

**FINISH:** Cabinet exterior, including door, shall be a #3 uniform finish. Cavity interior shall be polished stainless steel. Control panel face plate shall be smudge-resistant polyester film, ensuring maximum ease in cleaning and maintenance of an attractive appearance.

**CSA LISTING:** Steamer shall be CSA (formerly CGA) design certified

**SANITATION:** Steamer shall be designed and manufactured to meet NSF requirements and all known health codes. Steamer shall be NSF listed.

**CONTROLS:** Steamer controls shall include an on-off rocker switch; electronic timer, with continuous steam, timed steam and stop buttons; READY light which indicates when cavity is warm and ready for steaming.

**PERFORMANCE FEATURES:** Each steamer cavity shall have a powerful, side-mounted blower to increase steam velocity and provide efficient steam distribution throughout the cavity and between loaded pans. Steam generators shall deliver 100,000 BTU/hr of power input per 2-1/2" deep steam pan. Steamer shall have a steam lid positioned over each steam generating reservoir to ensure that adding/removing food does not lower the

water temperature. Heat up time to READY shall typically be 15 minutes or less. Cavity is kept warm and ready for instant steam between loads. No cavity warm up required after READY light comes on.

### ATMOSPHERIC STEAM GENERATING RESERVOIR:

Each steamer shall have a gas-heated steam generating reservoir to provide atmospheric steam to the cavity at a temperature of approximately 212° F. The high-efficiency steam generating reservoirs shall have water sensors. Gas heaters shall have infrared burners with a firing rate of 100,000 BTU/hr. Acidic products and other commercial chemicals shall not be used to clean the steamer. A daily wipe down of the steamer cavity, steam lid and water probes is sufficient to maintain optimal operation of the steamer. However, Groen Descaler or approved equal may be required.

### PAN CAPACITY:

Pan Size/ Type	Total	Total
12 x 20 x 1"	20	40
12 x 20 x2 1/2"	10	20
12 x 20 x 4"	6	12
13 x 18 bake pan	20	40
18 x 26 bake pan	10	20

**INSTALLATION:** Each steamer shall require natural or propane (specify) gas service via a 1/2 NPT gas supply line or approved equivalent. Each cavity shall have (2) 3/4" NH cold water supply line connections and a single 2-1/2" free venting drain connection. Each steamer shall require 115 Volt, single-phase electrical service.

### WATER SUPPLY REQUIREMENTS:

Steamer must be connected to an on-site water supply. Water supply at 30 - 60 PSIG with flow at .75 - 1.5 GPM per cavity.

**ORIGIN OF MANUFACTURE:** Designed and manufactured in the United States.

PROJECT NAME:

LOCATION:

ITEM NO:

QTY:

MODEL NO:

AIA NO:

SIS NO:

20-Pan Boilerless Convection Steamer (10 pans per cavity), double-stacked, stand-mounted, stainless steel, self-contained, gas heated. (Model (2)SSB-10GF shown)



### OPTIONS/ACCESSORIES:

- Flanged Foot Kit (for support stand)
- Caster Kit (for support stand)
- High Altitude Kit (above 2000', specify)
- Heat Shield Kits
- Single water connection

**SmartSteam100**  
**146576 RevK**  
Revised 03/17



P/N 146346 REV F

**SERVICE CONNECTIONS & NOTES:**

- ① DRAIN CONNECTIONS: 2 1/2" [64] TUBE FREE VENTING DO NOT CONNECT DIRECTLY TO DRAIN. ALLOW 2" AIR GAP
- ② GAS CONNECTION: 1/2" FPT ONE EACH GAS LINE MUST DELIVER 100,000 BTU'S MINIMUM EACH UNIT
- ③ WATER SUPPLY: 3/4" MALE HOSE (2) CONNECTION 30-60 PSIG WITH FLOW RATE OF 1.50 GPM. ONE EACH MAIN & CONDENSATE, PRESSURE REGULATOR REQUIRED FOR WATER PRESSURE OVER 60 PSI

- ④ ELECTRICAL CONNECTION: 120VAC, 60Hz, 15AMP CONDUIT SIZE: (2)-13/16" HOLES (STRAIN RELIEF)
- ⑤ CLEARANCES:  
EACH SIDE = 2" [51]  
REAR = 6" [152]
- ⑥ DIMENSIONS IN BRACKETS [ ] ARE MM.
- ⑦ STEAM FREE ZONE: STEAMERS FLOOR DRAIN NOT TO BE LOCATED WITHIN ZONE. ALTERNATE EQUIPMENT THAT DRAIN CAUSING STEAM NOT TO BE DRAINED IN STEAM FREE ZONE
- ⑧ DO NOT INSTALL STEAMER OVER STEAM VENTING DRAINS
- ⑨ STEAM EXHAUST

EACH COMPARTMENT	NATURAL GAS	PROPANE GAS
RECOMMENDED INCOMING GAS FEED RATE	5" WC (1.2 KPa) MIN. 14" WC (3.5 KPa) MAX.	12" WC (3 KPa) MIN. 14" WC (3.5 KPa) MAX.
GAS OPERATING PRESSURE	4.25" W.C.	10.5" W.C.
MAX. INPUT BTU/HR	100,000	100,000

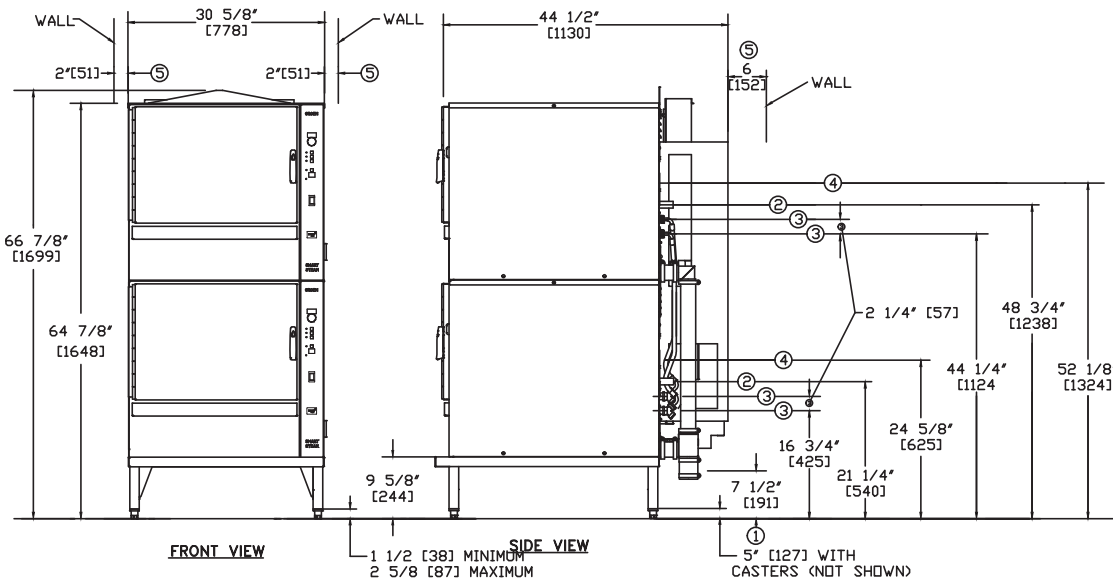
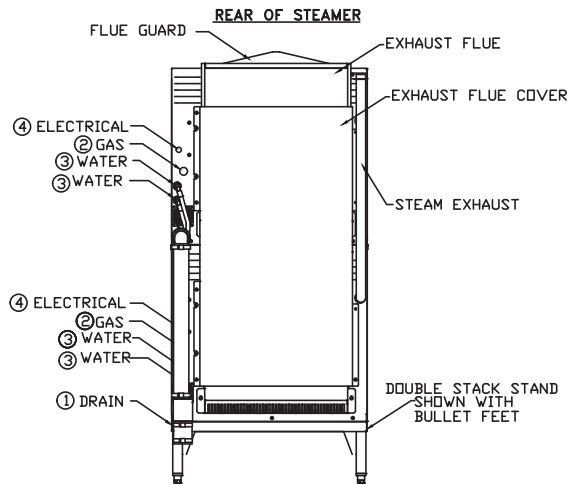
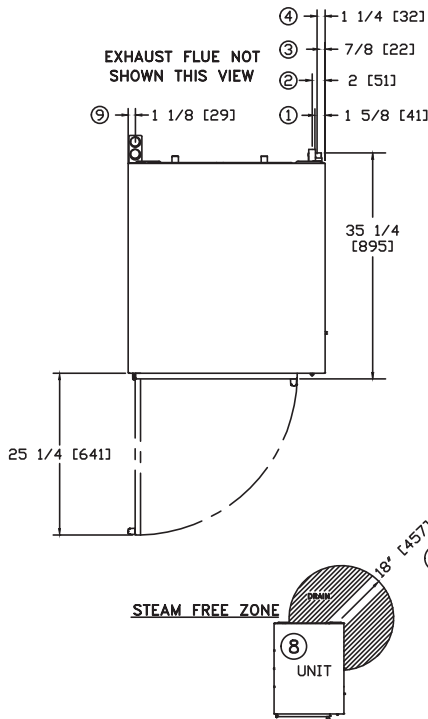

(2) SSB-10G 146346 REV F