



DBCA-18



**Intertek**  
 4004503  
 Conforms to ANSI/NSF STD 2

Project: _____	AIA# _____
Item #: _____ Qty: _____	SIS# _____
Model #: _____	

## Drainboard Cabinets

See reverse side for model number key

### Standard Features

- All stainless steel construction
- Adjustable stainless steel bullet feet
- One-piece, seamless top and backsplash featuring 1/4" radius corners for easy cleaning
- Door(s) features integral handle
- Lock(s) standard on models with a door(s)
- Available without door(s) (add suffix '-LD' to model number)
- Work surface consists of a drainboard top with drain pan and separate perforated insert for better air circulation.
- Intermediate shelf and floor are still removable after unit is plumbed and include radius corners for easy cleaning.
- Plumbing connection is made underneath the unit and does not interfere with shelf or floor.
- Smooth interior walls for easy cleaning and a finished appearance.
- All storage is on a level plane
- Also available with flat stainless steel filler board top in lieu of drainboard top. Substitute an "F" for the "D" in the model number when ordering

To view underbar installation instructions, please visit: [http://www.glastender.com/PDF/F-750-165\\_Underbar\\_Installation\\_Instructions.pdf](http://www.glastender.com/PDF/F-750-165_Underbar_Installation_Instructions.pdf)  
 To view cleaning and care instructions, please visit: [http://www.glastender.com/PDF/F-423-011\\_ss\\_clean\\_care.pdf](http://www.glastender.com/PDF/F-423-011_ss_clean_care.pdf)

<b>Specifications</b>	<b>Product Information</b>
-----------------------	----------------------------

*Drain*

- 1/2" welded tailpiece. Clear vinyl drain line is connected to the tailpiece at the factory. A 1/2" by 1/2" barbed plastic elbow is provided to make the connection at the bottom of the unit.

*Legs*

- 1-5/8" diameter, 16 gauge stainless steel
- Stainless steel bullet feet

*Materials*

- 20 gauge stainless steel parts include: all components unless otherwise noted
- 18 gauge stainless steel parts include: leg pads

Drainboard Cabinets have a bottom shelf, adjustable intermediate shelf, and drainboard work surface. They are available with or without doors. The models with doors come with a lock standard. The 12", 18" and 24" wide models only have one door and all other models have two doors.

<b>Glastender, Inc.</b> • 5400 N Michigan Rd • Saginaw, MI • 48604-9780 989.752.4275 • 800.748.0423 • Fax 989.752.4444 <a href="http://www.glastender.com">www.glastender.com</a>	Approval/Notes:
Specifications subject to change without notice. For current specifications please visit our website.	

# Drainboard Cabinets

## Dimensional Information

### "A" Depth-19" Deep Models

Model DBCA-18 shown

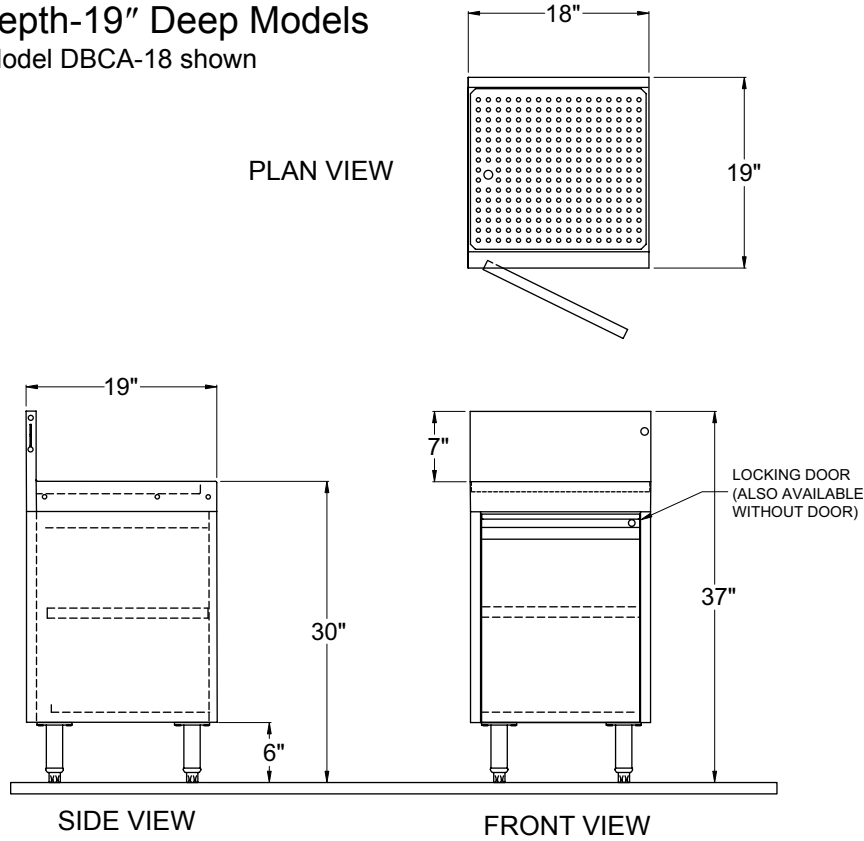

Model Number	Overall Length	Number of Doors
DBCA-12	12"	1
DBCA-18	18"	1
DBCA-24	24"	1
DBCA-30	30"	2
DBCA-36	36"	2
DBCA-42	42"	2
DBCA-48	48"	2

### "B" Depth-24" Deep Models

Model DBCB-18 shown

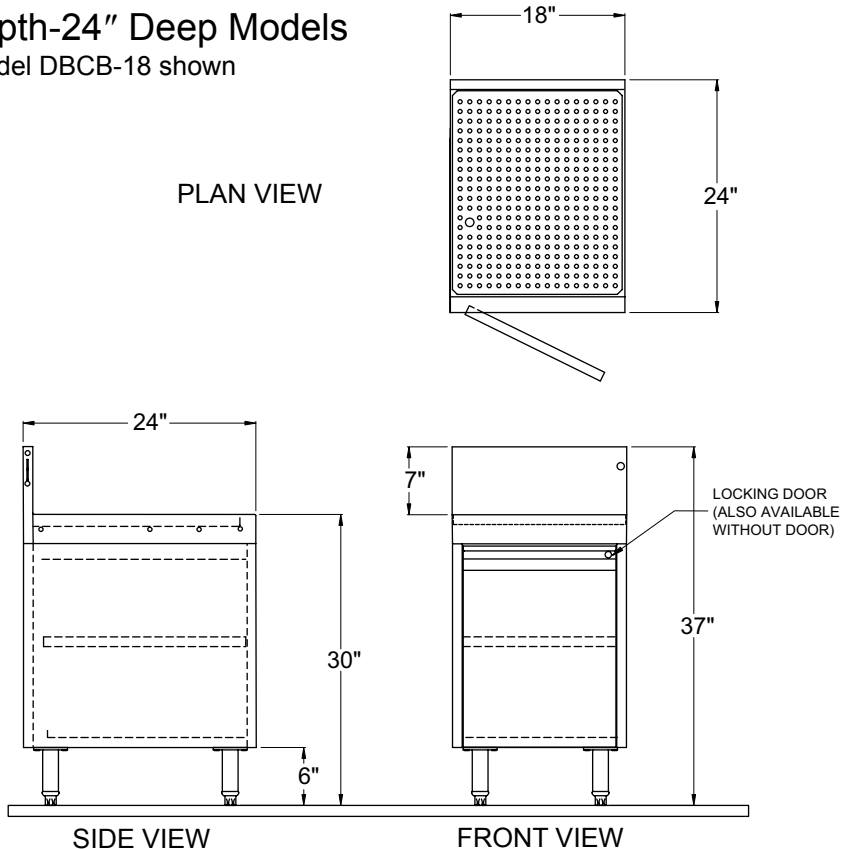

Model Number	Overall Length	Number of Doors
DBCB-12	12"	1
DBCB-18	18"	1
DBCB-24	24"	1
DBCB-30	30"	2
DBCB-36	36"	2
DBCB-42	42"	2
DBCB-48	48"	2