



**BEVERAGE-AIR**

Project: _____	AIA#
Item: _____	
Location: _____	SIS#
Approved: _____	

**ST SCHOOL MILK COOLERS**  
ST49N Dual Access, Cold Wall

**MODELS:**  
ST49N-1-W-02

ST49N Dual Access, Cold Wall : School Milk Series

**3 Year Parts/Labor Warranty**  
**Additional 2 Year Compressor Warranty**

**CABINET CONSTRUCTION**

- White coated steel exterior and stainless steel interior
- Lids, doors, adjustable hinges and door latches made from stainless steel are standard on all units
- Full electronic Control
- Heavy-duty epoxy coated steel wire floor racks standard
- Floor drain is centrally located for easy cleaning, connecting to drain hose with hose adapter
- Flexible compression door gaskets ensure tight seal
- Self-latching doors/lids with safety bumpers
- Exterior thermometer
- Cylinder lock
- Dual access, cold wall milk coolers are designed to hold milk between 36°F to 38°F until ready to serve.
- Units are not designed for overnight storage of milk



**ST49N -1-W-02**

**OPTIONS & ACCESSORIES**

- Stainless steel exterior
- Wrap around & corner bumpers
- Graphics

**REFRIGERATION SYSTEM**

- Refrigeration system uses R404A refrigerant to comply with all environmental concerns
- Automatic non-electric defrost
- Epoxy coated evaporator coil



3779 Champion Blvd., Winston-Salem, NC 27105  
1-888-845-9800 Fax: 1-336-245-6453  
Beverage-Air.com sales@bevair.com



# BEVERAGE-AIR

## ST Series—School Milk Cooler

Models: ST49N-1-W-02

MODEL	ST49N-1-W-02
<b>EXTERNAL DIMENSIONAL DATA</b>	
Width Overall	49"
Depth Overall	31 1/4"
Depth Overall with Lids/Doors Extended	61"
Height Overall with Casters	41 1/8"
Number of Lids/Doors	4
<b>INTERNAL DIMENSIONAL DATA</b>	
NET Capacity (cubic ft.)	20
Internal Width Overall (in)	46"
Internal Depth Overall (in)	27"
Internal Height Overall (in)	25 1/2"
<b>CASE CAPACITIES</b>	
13" x 13" x 11"	12
19" x 13" x 11"	8
<b>ELECTRICAL DATA</b>	
Full Load Amperes 115/60/1	7.5
<b>REFRIGERATION DATA</b>	
Horsepower	1/4
<b>WEIGHT DATA</b>	
Gross Weight (Crated lbs)	335 lbs
Height - Crated	47"
Width - Crated	52"
Depth - Crated	34"

Note: Unit is not meant for overnight storage.

### Model Views

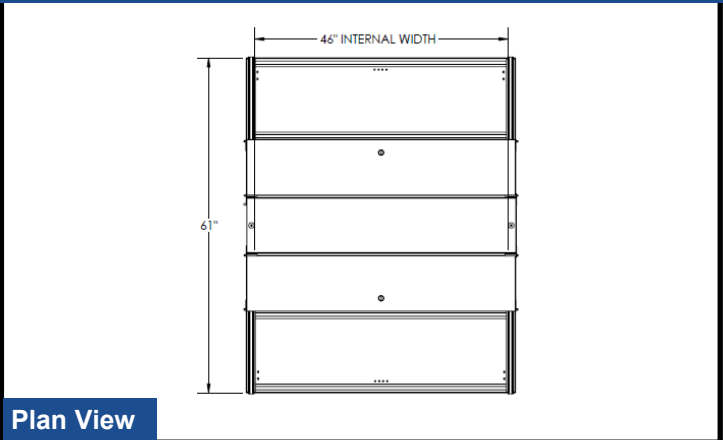

Plan View

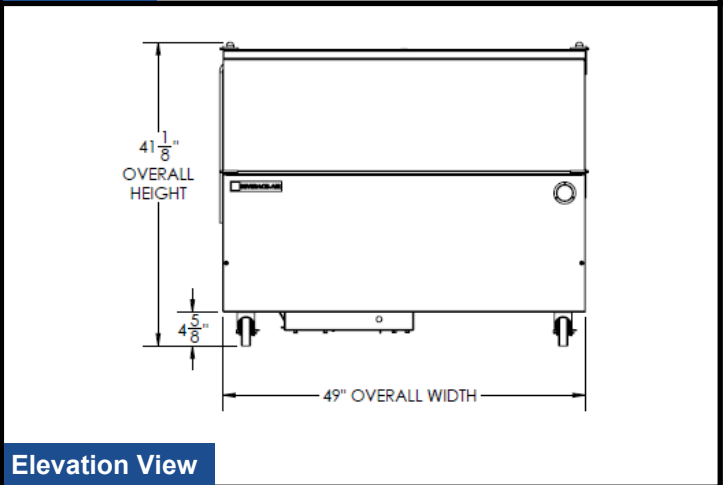

Elevation View

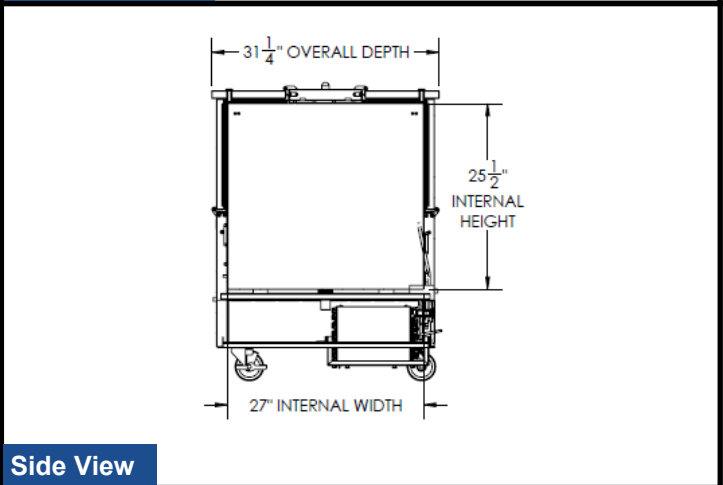

Side View

### ELECTRICAL CONNECTION



115/60/1  
NEMA-5-15P

Units pre-wired at factory and include 8' long cord and plug set.



an Ali Group Company



The Spirit of Excellence

3779 Champion Blvd., Winston-Salem, NC 27105  
1-888-845-9800 Fax: 1-336-245-6453  
Beverage-Air.com sales@bevair.com