



BEVERAGE-AIR

Project: _____	AIA#
Item: _____	
Location: _____	SIS#
Approved: _____	

SM SCHOOL MILK COOLERS

SM49N Single Access, Cold Wall

MODELS:
SM49N-1-W



SM49N-W

3 Year Parts/Labor Warranty
Additional 2 Year Compressor Warranty

CABINET CONSTRUCTION

- White coated steel exterior
- Interior is galvanized steel with stainless steel floor for maximum milk crate support.
- Lids, doors, adjustable hinges and door latches made from stainless steel are standard on all units
- Full electronic Control
- Heavy-duty epoxy coated steel wire floor racks standard
- Floor drain is centrally located for easy cleaning, connecting to drain hose with hose adapter
- Flexible compression door gaskets ensure tight seal
- Self-latching doors/lids with safety bumpers
- Exterior thermometer
- Cylinder lock
- 4" Heavy-duty plate casters (2 with locks)
- Maintains continuous milk temperature between 36° - 38°F

OPTIONS & ACCESSORIES

- Stainless steel interior
- Stainless steel exterior
- Wrap around & corner bumpers
- Graphics

REFRIGERATION SYSTEM

- Refrigeration system uses R404A refrigerant to comply with all environmental concerns
- Automatic, non-electric defrost
- Epoxy coated evaporator coil

SM49N Single Access, Cold Wall : School Milk Series



3779 Champion Blvd., Winston-Salem, NC 27105
1-888-845-9800 Fax: 1-336-245-6453
Beverage-Air.com sales@bevair.com



BEVERAGE-AIR

SM Series—School Milk Cooler

Models: SM49N-1-W

MODEL	SM49N-1-W
EXTERNAL DIMENSIONAL DATA	
Width Overall	49"
Depth Overall with Lids/Doors Extended	30 5/8"
Height Overall with 4" Casters	41 1/8"
Number of Lids/Doors	2
INTERNAL DIMENSIONAL DATA	
NET Capacity (cubic ft.)	20
Internal Width Overall (in)	46"
Internal Depth Overall (in)	27"
Internal Height Overall (in)	25 3/4"
CASE CAPACITIES	
13" x 13" x 11"	12
19" x 13" x 11"	8
ELECTRICAL DATA	
Full Load Amperes 115/60/1	7.5
REFRIGERATION DATA	
Horsepower	1/4
WEIGHT DATA	
Gross Weight (Crated lbs)	339 lbs
Height - Crated	44"
Width - Crated	52"
Depth - Crated	34"

Note: Unit is not meant for overnight storage.

Model Views

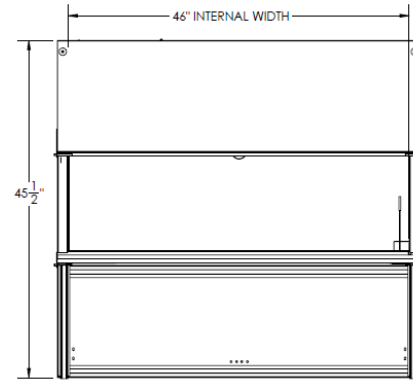

Plan View

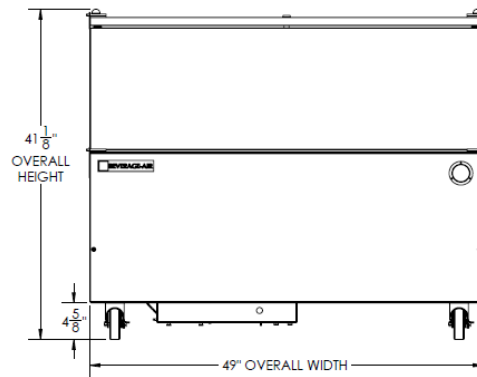

Elevation View

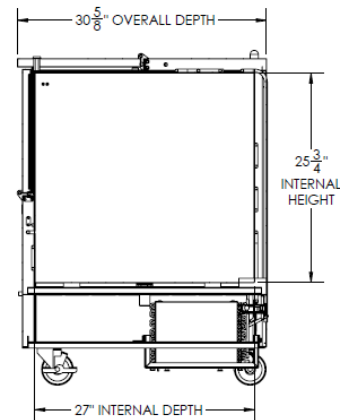

Side View

ELECTRICAL CONNECTION



115/60/1
NEMA-5-15P

Units pre-wired at factory and include 8' long cord and plug set.



an Ali Group Company



The Spirit of Excellence

3779 Champion Blvd., Winston-Salem, NC 27105
1-888-845-9800 Fax: 1-336-245-6453
Beverage-Air.com sales@bevair.com